

XPert[®] Balance & Bulk Powder Enclosures



Protecting your
laboratory environment

LABCONCO



XPert® Balance Enclosures and Bulk Powder Enclosures OVERVIEW

Patented XPert line of Balance Enclosures and Bulk Powder Enclosures maximizes containment of toxic airborne powders and other particulates as well as fumes and vapors. XPert Enclosures are well suited for pharmaceutical research and other laboratory applications involving weighing or bulk transfer of toxic substances. The innovative, aerodynamic designs of the air foil, upper sash foil, zone-perforated rear baffle and side-entry air foils work together to significantly reduce concentrations of contaminants in the operator's breathing zone. Labconco engineers carefully selected materials of construction and design details that support safe, energy-efficient toxic substance handling.*



The XPert line of Balance Enclosures maximizes containment of hazardous particulates during weighing operations.

Table of Contents

Overview	2
Selection Guide	7
XPert Filtered Balance Systems	8
XPert Filtered Balance Stations	14
XPert Balance Enclosures	20
XPert Easy-Order	26
XPert Bulk Powder Filtered Systems, Filtered Stations and Enclosures	28
FilterMate Portable Exhausters	36
FilterMate Carbon and HEPA Filters	38
Protector® Standard Storage Cabinets	39
Telescoping Base Stands	40
Accessories	41
Blowers	44
Ductwork	45

*U.S. Patent No. 6,461,233
Additional patent pending



XPert® Balance Enclosures and Bulk Powder Enclosures

OVERVIEW

Containment-Enhancing Features

Side-view illustration of XPert Balance Enclosure depicting laminar airflow

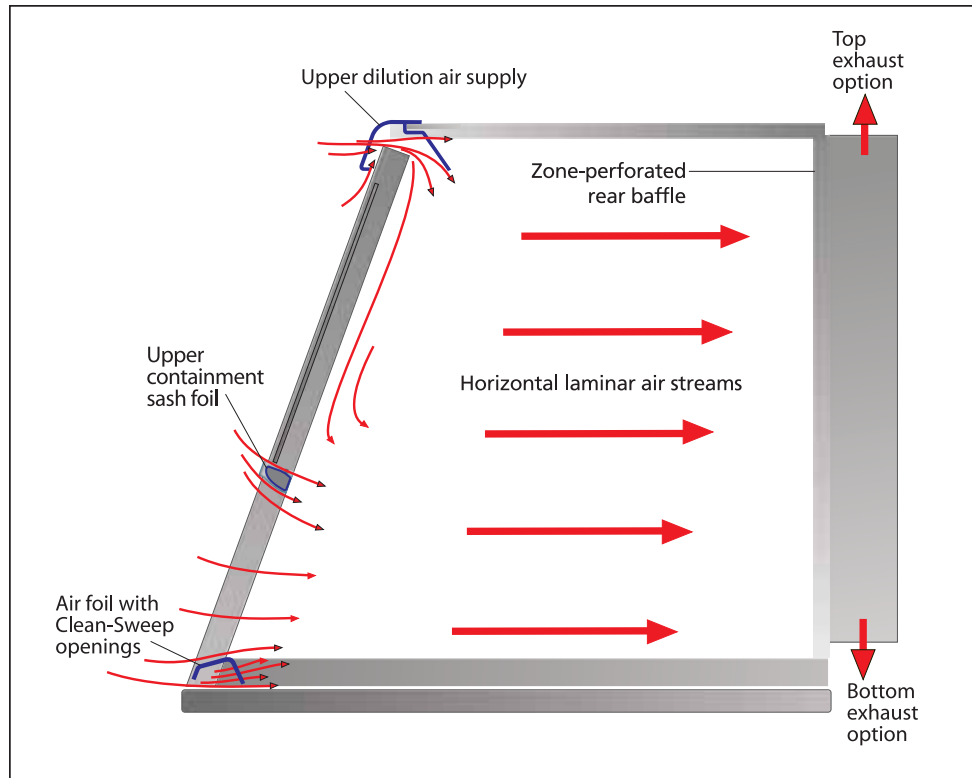

Clean-Sweep™ Air Foil

The aerodynamic air foil allows air to sweep the work surface for maximum containment. Clean-Sweep openings pull inflow air from under the air foil so that clean air continually flows through the air foil creating a constant protective contaminant barrier. Should the operator inadvertently block the airflow, air continues to pass under the air foil and through the Clean-Sweep openings.



Side-Entry Air Foils

Aerodynamic air foils located on either side of the sash opening direct clean airflow into the chamber.



Upper Dilution Air Supply

The upper dilution air supply introduces air from above the work area, which

bathes the back of the sash with clean air and directs concentrations away from the sash opening.

Upper Containment Sash Foil

A small gap directly above the aerodynamic sash handle allows high velocity air to bleed into the chamber, reducing turbulence and directing concentrations away from the user's breathing zone.



XPert® Balance Enclosures and Bulk Powder Enclosures

OVERVIEW

Table 1
Surface Resistivity

Material	Surface Resistivity	Example
Conductive	0 – 10 ⁵ Ω per square	Skin, Metals
Static Dissipative	10 ⁵ – 10 ⁹ Ω per square	Glass
Antistatic	10 ⁹ – 10 ¹² Ω per square	Polyethylene Bag
Insulative	≥10 ¹² Ω per square	Acrylic Box, Packing Foam, Styrofoam

Since static electricity is a surface phenomenon, materials can be classified by their surface resistivity measured in ohms per square. The table above lists the surface resistivity of various classes of material. Glass and metal have less surface resistivity than acrylic.

Patented* Zone-Perforated Rear Baffle

The baffle with three zoned sections of perforations directs inflow air in non-turbulent laminar air streams from the



sash opening to the baffle in a single pass. The lower section provides more airflow at the bottom to help minimize the potential for air to roll forward toward the sash opening.

Static-Dissipating Construction

Static charges can lead to errors in weighing and particulates being attracted to surfaces, resulting in greater potential for cross-contamination and loss of containment. Unlike acrylic, which is highly insulative and has a strong affinity for charged particles, XPert Enclosures are constructed of static-dissipative tempered safety glass and epoxy-coated metal. (Table 1)

Verified Performance

Independent tests were performed to verify the powder containment and balance stability of XPert Enclosures. These test results are included in the Validation Package, which is available upon request.

Containment-enhancing features allow XPert Enclosures to operate at face velocities from 60 to 100 fpm. Independent testing confirms that the XPert Balance Enclosures contains both particulate and gaseous contaminants.

SafeBridge Consultants, Incorporated

verified the performance of the XPert Balance Enclosures, XPert Filtered Balance System and XPert Bulk Powder Filtered System confirming their ability to provide excellent containment of powders.

Naproxen sodium, a non-potent active pharmaceutical ingredient, was selected for the study because it is safe to handle, readily detectable in air at low concentrations, has a high dustiness quotient and challenging electrostatic properties. The XPert Balance Enclosures and XPert Filtered Systems demonstrated effective containment when repeated small scale weighing operations were performed by different operators with varied levels of work practice. The enclosures demonstrated excellent containment when used by operators using proper technique. While no enclosure can compensate for improper technique, these tests confirm that the XPert Balance Enclosure, XPert Filtered Balance System and XPert Bulk Powder Filtered System provide safe working environments.

ECT, Incorporated conducted modified ASHRAE 110-1995 testing on the XPert Balance Enclosure and Labconco Corporation conducted modified ASHRAE 110-1995 testing on the XPert Filtered Balance Systems and Stations. Both concluded that the enclosures maintained containment at face velocities greater than

50 fpm. Average concentrations during tracer gas tests were less than 0.05 ppm and no escape was observed during the smoke tests. Since Labconco recommends a minimum face velocity of 60 fpm, the acceptable containment at 50 fpm provides a margin of safety. The built-in airflow monitor, digital or analog depending on the enclosure, alerts the user should velocity approach 50 fpm.

Chemir Analytical Services conducted balance stability tests on the XPert Filtered Balance System mounted on a Solid Epoxy Work Surface. No marble slab was used.

The enclosure was tested while operating at three face velocities — 0, 78 fpm (factory setting), and 100 fpm. Samples of 5 mg, 50 mg and 100 mg were weighed on an analytical balance located inside the enclosure. Test results were excellent and confirm that the XPert Filtered Balance System, including its built-in blower and the airflow through the enclosure, caused no detectable instability to the balance. The weight of each sample was stable to five decimal places.

Bag-In/Bag-Out HEPA Filter Disposal System

Unique to the XPert Filtered Systems, XPert Filtered Stations and FilterMate Portable Exhausters is the true bag-in/



bag-out HEPA filter system. Using a built-in sealed bag with gloves, a technician can remove a contaminated filter without exposing the filter or contaminated plenum to personnel or the environment. On XPert Filtered Balance Systems and

*U.S. Patent No. 6,461,233



XPert® Balance Enclosures and Bulk Powder Enclosures

OVERVIEW



The XPert Filtered Balance System is available in 2', 3', 4', 5' and 6' widths.



Since the XPert Filtered Balance System includes a built-in blower and HEPA filter mounted in the upper plenum, no outside ducting is required.

Stations, the filter is accessible by removing the front panel. On FilterMate Portable Exhausters the filter is accessible from the back without detaching the FilterMate from the XPert Balance Enclosure.

Select the Right XPert for Your Application

The XPert line of balance enclosures was designed to provide user protection during weighing operations that generate toxic airborne particulates. Interior dimensions of any XPert enclosure accommodate large micro or analytical balances.

The XPert line of bulk powder enclosures was designed to provide user protection from toxic airborne particulates generated during bulk powder transfer and weighing operations. Selecting the right XPert enclosure depends on factors such as the user's application, airborne containment removal needs, space limitations and ducting options.

XPert Filtered Balance Systems and Bulk Powder Systems are self-contained enclosures with a built-in blower and HEPA filter mounted above the work area. Because a separate blower module is not required, these enclosures require less overall bench space than other models. Since HEPA filtered air may be returned to the laboratory, XPert Filtered Systems are ideal for installations in areas surrounded by interior walls or where ducting is not feasible. Accessory Trace Odor Carbon Filters may be used with these enclosures to trap small amounts of gas from organic solvents, aldehydes or amines used in conjunction with particulate-generating work. XPert Filtered Balance Systems are available in 2', 3', 4', 5' and 6' widths. XPert Filtered Bulk Powder Systems are available in 5' and 6' widths.

XPert Filtered Balance Stations and Bulk Powder Stations are designed to be connected to a remote blower and ducted to the outside. The remote blower,

which is sold separately, must be sized to fit individual requirements for face velocity and duct run. A HEPA filter installed in these enclosures' upper plenum traps particulate contaminants in the exhaust air. Because exhaust air does not return to the room, XPert Filtered Balance Stations may be used to remove light chemical fumes or to control odors. These enclosures have the same compact footprint as XPert Filtered Balance Systems. Since they are ducted to the outside, they require a permanent location in the laboratory, or a flexible hose connected to a house exhaust. XPert Filtered Balance Stations are available in 2', 3', 4', 5' and 6' widths. XPert Filtered Bulk Powder Stations are available in 5' and 6' widths.

XPert Balance and Bulk Powder Enclosures feature flexible ducting options. Collars on the top and bottom allow connection to ductwork and remote blower for exhausting to the outside. Use of the bottom exhaust collar hides the



XPert® Balance Enclosures and Bulk Powder Enclosures

OVERVIEW

ductwork behind casework, enhancing visibility throughout the laboratory. Depending on the application, XPert Enclosures that are hard-ducted to the outside may require an in-line HEPA filter.

If outside ducting is not feasible, the XPert Balance Enclosure may be connected from the top or bottom to the FilterMate Portable Exhauster, which houses a HEPA filter, carbon filter or combination of both filters. The FilterMate provides up to 100 fpm face velocity for the XPert

Enclosure and only one FilterMate is needed for any 2', 3' or 4' XPert. Multiple FilterMates may be connected to XPert Enclosures in 5', 6' or 8' widths. Since FilterMate Portable Exhausters accommodate large carbon filters with longer dwell times than the Trace Odor Filters used with the XPert Filtered Systems, XPert Enclosures connected to FilterMate Portable Exhausters may be used with a wide variety of applications involving organic solvents, formaldehyde, ammonia or amines. See page 38 for an Application

Matrix. XPert Balance Enclosures are available in 2', 3', 4', 5', 6' and 8' widths. XPert Bulk Powder Enclosures are available in 5', 6' and 8' widths.

Labconco also offers the **XPert Easy-Order** consisting of the XPert Balance Enclosure, Black Solid Epoxy Work Surface and FilterMate Portable Exhauster with HEPA Filter. Add a supporting base and the XPert Easy-Order has all the components necessary to make a complete system. XPert Easy-Order is offered in 2', 3' and 4' widths.



The XPert Easy-Order includes the XPert Balance Enclosure, Black Solid Epoxy Work Surface and FilterMate Portable Exhauster. Supporting base is not included.



The XPert line of Bulk Powder Enclosures include the 6' XPert Bulk Powder Filtered System shown above as well as the XPert Bulk Powder Filtered Stations and Enclosures. All models include an integral base stand, airflow monitor, transfer caddy, push button-operated electric hydraulic lift mechanism, and left side-mounted waste chute.



XPert® Balance Enclosures and Bulk Powder Enclosures SELECTION GUIDES

The Selection Guide below provides at-a-glance descriptions of the various XPert Balance Enclosures offered in this catalog.

Balance Enclosure Selection Guide				
	XPert Filtered Balance System	XPert Filtered Balance Station with Remote Blower	XPert Balance Enclosure with FilterMate Portable Exhauster or XPert Easy-Order	XPert Balance Enclosure with Remote Blower
	Pages 8-13	Pages 14-19	Pages 20-27	Pages 20-27
Exterior Nominal Widths	2', 3', 4', 5', 6'	2', 3', 4', 5', 6'	2', 3', 4'	2', 3', 4', 5', 6', 8'
Exhausts to:	Room or Outside*	Outside	Room or Outside**	Outside
Portable	•		•	
Small Footprint	•	•		•
Low Profile			•	•
Applications:				
Weighing potent powders	•	•	Requires HEPA Filter	•
Drug compounding/research	•	•	Requires Carbon Filter	•
Potent powders with trace chemicals	Requires Trace Odor Control Carbon Filter	•	Requires Carbon Filter	•
Nuisance odors including trace quantities of solvents, aldehydes, ammonia or amines	Requires Trace Odor Control Carbon Filter	•	Requires Carbon Filter	•
Light-duty solvent, formaldehyde or ammonia use		•	Requires Carbon Filter	•
Light-duty liquid acid use		•		•

* XPert Filtered Balance Systems may be thimble-ducted to the outside with the addition of a Canopy Connection, ductwork and connection to house exhaust or a remote blower.

** Most FilterMate Portable Exhausters exhaust to the room. FilterMate Portable Exhausters #3970002 and #3970022 are designed to be exhausted to the outside.

The Selection Guide below provides at-a-glance descriptions of the various XPert Bulk Powder Enclosures offered in this catalog.

Bulk Powder Enclosure Selection Guide				
	XPert Bulk Powder Filtered System	XPert Bulk Powder Filtered Station with Remote Blower	XPert Bulk Powder Enclosure with FilterMate Portable Exhausters	XPert Bulk Powder Enclosure with Remote Blower
	Pages 28-31	Pages 28-29, 32-33	Pages 28-29, 34-35	Pages 28-29, 34-35
Exterior Nominal Widths	5', 6'	5', 6'	5', 6', 8'	5', 6', 8'
Exhausts to:	Room or Outside*	Outside	Room or Outside**	Outside
Low Profile			•	•
Applications:				
Pigments & dyes	•	•	Requires HEPA Filter	•
Dry chemical manufacturing	•	•	Requires HEPA Filter	•
Food & flavoring formulation	•	•	Requires HEPA Filter	•
Potent powders with trace chemical vapors	Requires Trace Odor Control Carbon Filter	•	Requires Carbon Filter	•
Nuisance odors including trace quantities of solvents, formaldehyde, ammonia or amines	Requires Trace Odor Control Carbon Filter	•	Requires Carbon Filter	•
Light-duty liquid acid use		•		•

* XPert Filtered Balance Systems may be thimble-ducted to the outside with the addition of a Canopy Connection, ductwork and connection to house exhaust or a remote blower.

** Most FilterMate Portable Exhausters exhaust to the room. FilterMate Portable Exhausters #3970002 and #3970022 are designed to be exhausted to the outside.





XPert® Filtered Balance Systems

FEATURES & BENEFITS

XPert Filtered Balance Systems provide user protection by keeping powders and particulates contained during procedures involving powders. **The built-in blower and exhaust HEPA filter mounted in the upper plenum conserves space while isolation supports minimize blower vibration.** Since HEPA filtered air is returned to the laboratory, these enclosures have the

added benefits of low installation costs, portability and no required outside ducting. Interior dimensions accommodate large analytical and micro balances. Containment-enhancing features ensure that potent powders frequently found in pharmaceutical, dry chemical, and industrial hygiene applications are kept away from the operator. Systems are available in 2', 3', 4', 5' and 6' widths.

True bag-in/bag-out HEPA filter disposal system allows for safe filter replacement. See page 4.

Space-saving design. Impeller and HEPA filter are contained within the enclosure's upper plenum for a smaller overall footprint than a separate enclosure and exhauster can offer.

Built-in airflow monitor alerts the user to face velocities outside of preset range. Models without monitor are also available.

Quiet operation as low as 48 decibels.

Optimal HEPA filter location permits leak-detection scan of entire surface.

Static-dissipative epoxy-coated aluminum frame and steel rear plenum and baffle. No unreliable plastic-to-plastic bonding is used.

Front-mounted pressure gauge helps determine HEPA filter loading.

Upper dilution air supply sweeps clean air to the back of sash to keep contaminants away from the operator. See page 3.

Tempered safety glass provides better fire, scratch and chemical resistance than acrylic and dissipates static charge.

Ergonomic angled sash for comfortable viewing.

Side-entry air foils allow air to sweep interior surfaces to enhance containment. See page 3.

Upper containment sash foil directs contaminants away from the user's breathing zone. See page 3.

Deep 23.4" interior easily accommodates large analytical balances. Some 5' and 6' models are available with 30" interior depths.

Patented* Clean-Sweep™ air foil allows air to sweep the work surface to maximize containment. See page 3.

Built-in impeller has vibration-isolation supports to minimize disturbance to sensitive balances.

Intrinsically safe. The positive pressure impeller is surrounded by a negative pressure plenum so that if a leak should develop, the unfiltered air is captured and refiltered.



Patented* rear baffle with zones of perforations promotes horizontal laminar airflow. See page 4. The baffle pivots down for cleaning.

Optional left-side mounted waste chute isolates contaminated waste in a sealable bag. Some 5' and 6' models include a waste chute. Contact Labconco for ordering information on other models.



Exclusive feature
*U.S. Patent No. 6,461,233



XPert® Filtered Balance Systems

SPECIFICATIONS



XPert Filtered Balance System 3950402 is shown with Black Solid Epoxy Dished Work Surface 3909902 and Protector Standard Storage Cabinets 9900300. Work surface and base cabinet must be ordered separately.



- Intrinsically safe, negative pressure design.
- Pressure gauge.
- Space-saving design. No separate filtered exhauster is required.
- Upper diffuser screen.
- Quiet operation (see chart below).
- Glacier white and gray, dry powder epoxy-coated aluminum frame and steel rear plenum and baffle. No unreliable plastic-to-plastic bonding is used.

- Pre-wired fluorescent lamp and switches for blower and light.
- 1/4" thick tempered safety glass front sash and sides.
- Ergonomic angled and hinged, pivoting sash with wiping seal. Sashes on 5' and 6' models incorporate an external gas-assist lift.

- Models with 9.4" sash opening height have 16.5" locking height and 19.0" maximum loading height. Models with 12.0" sash opening height have 25.75" locking height and 28.25" maximum loading height.
- Two utility ports for pass-through of electrical cords.
- Particulate containment independently verified by SafeBridge Consultants, Inc.
- Validation package available at www.labconco.com containing balance stability, powder containment and modified ASHRAE 110-1995 Test Reports; Installation Qualification/Operation Qualification (IQ/OQ) Protocol; and Maintenance Log.

All models feature:

- Deep interior of 23.4" or 30.0" depending on the model.
- Ergonomic air foil with aerodynamic Clean-Sweep* airflow openings.
- Upper dilution air supply.
- Upper containment sash foil.
- Zone-perforated, pivoting rear baffle.*
- Side-entry air foils.
 - Exhaust HEPA filter, 99.99% efficient on particles 0.3 micron in size.
- Top-accessible HEPA filter for leak scanning of entire surface.
- True bag-in/bag-out filter disposal system (requires certified technician).
- Built-in blower with dynamically-balanced, vibration-isolated motorized impeller and speed control. Blower has a 40% reserve so that the speed may be adjusted as needed by a certified technician as the filter loads.

Exclusive feature

*U.S. Patent No. 6,461,233

- UL 3101-1/61010-1
- CAN/CSA C22.2 No. 1010.1
- CE Conformity Marking (230 volt models)

Models with Guardian Airflow Monitor include:

- Guardian Airflow Monitor that continuously monitors airflow with a green LED that glows when airflow is within set point range and a red LED that glows and an audible alarm that sounds when airflow is outside set point range.

Models with Guardian 1000 Digital Airflow Monitor include:

- Guardian 1000 Digital Airflow Monitor that continuously monitors airflow and provides a digital readout of actual face velocity. An audible/visual alarm alerts the operator when airflow is outside set point range. RS232 communications port allows connection to user-supplied computer.

5' and 6' models with 35.5" exterior depth include:

- Left-side mounted waste chute. Bags not included. Minimum bag size required: 10" x 16".

All models require:

- Work surface. See page 41.
- Supporting base. See pages 39-40.

Optional accessories for on-site installation include:

- Trace Odor Carbon Filters. See page 41.
- Utility Shelves, Bottle Holder and Tissue Holder. See page 42.
- Canopy Connections. See page 43.
- Remote Blowers. See page 44.
- Ductwork. See pages 45-46.
- Waste Chute Bags. Contact your laboratory supply dealer.

All models conform to the following regulations and standards:

- SEFA 1-2002
- Modified ASHRAE 110-1995
- ANSI Z9.5-1993

Nominal Width	Sash Opening Ht.	Total Exhaust CFM and Sound Levels					
		100 fpm	db(A)	80 fpm	db(A)	60 fpm	db(A)
2 Feet	9.4"	145	53-58	115	50-55	85	48-53
3 Feet	9.4"	220	58-61	175	53-58	130	48-53
4 Feet	9.4"	295	62-66	235	58-61	175	49-54
5 Feet	12.0"	480	63-67	385	58-63	290	52-56
6 Feet	12.0"	580	67-69	465	61-63	350	55-57



XPert® Filtered Balance Systems

2', 3' AND 4' MODELS ORDERING INFORMATION & DIMENSIONAL DATA

XPert® Filtered Balance Systems

Nominal Width	Catalog Number	Overall Dimensions	Interior Dimensions	Electrical Requirements	Built-In Airflow Monitor	Shipping Weight lbs./kg
2'	3950200	24.0" w x 29.0" d x 37.1" h	21.6" w x 23.4" d x 22.7" h	115 volts, 60 Hz	None	175/79
2'	3950201	24.0" w x 29.0" d x 37.1" h	21.6" w x 23.4" d x 22.7" h	115 volts, 60 Hz	Guardian	180/82
2'	3950202	24.0" w x 29.0" d x 37.1" h	21.6" w x 23.4" d x 22.7" h	115 volts, 60 Hz	Guardian 1000 Digital	180/82
2'	3950220*	24.0" w x 29.0" d x 37.1" h	21.6" w x 23.4" d x 22.7" h	230 volts, 50 Hz no plug	None	175/79
2'	3950221*	24.0" w x 29.0" d x 37.1" h	21.6" w x 23.4" d x 22.7" h	230 volts, 50 Hz no plug	Guardian	180/82
2'	3950222*	24.0" w x 29.0" d x 37.1" h	21.6" w x 23.4" d x 22.7" h	230 volts, 50 Hz no plug	Guardian 1000 Digital	180/82
3'	3950300	36.0" w x 29.0" d x 37.1" h	33.6" w x 23.4" d x 22.7" h	115 volts, 60 Hz	None	225/102
3'	3950301	36.0" w x 29.0" d x 37.1" h	33.6" w x 23.4" d x 22.7" h	115 volts, 60 Hz	Guardian	230/104
3'	3950302	36.0" w x 29.0" d x 37.1" h	33.6" w x 23.4" d x 22.7" h	115 volts, 60 Hz	Guardian 1000 Digital	230/104
3'	3950320*	36.0" w x 29.0" d x 37.1" h	33.6" w x 23.4" d x 22.7" h	230 volts, 50 Hz no plug	None	225/102
3'	3950321*	36.0" w x 29.0" d x 37.1" h	33.6" w x 23.4" d x 22.7" h	230 volts, 50 Hz no plug	Guardian	230/104
3'	3950322*	36.0" w x 29.0" d x 37.1" h	33.6" w x 23.4" d x 22.7" h	230 volts, 50 Hz no plug	Guardian 1000 Digital	230/104
4'	3950400	48.0" w x 29.0" d x 37.1" h	45.6" w x 23.4" d x 22.7" h	115 volts, 60 Hz	None	275/125
4'	3950401	48.0" w x 29.0" d x 37.1" h	45.6" w x 23.4" d x 22.7" h	115 volts, 60 Hz	Guardian	280/127
4'	3950402	48.0" w x 29.0" d x 37.1" h	45.6" w x 23.4" d x 22.7" h	115 volts, 60 Hz	Guardian 1000 Digital	280/127
4'	3950420*	48.0" w x 29.0" d x 37.1" h	45.6" w x 23.4" d x 22.7" h	230 volts, 50 Hz no plug	None	275/125
4'	3950421*	48.0" w x 29.0" d x 37.1" h	45.6" w x 23.4" d x 22.7" h	230 volts, 50 Hz no plug	Guardian	280/127
4'	3950422*	48.0" w x 29.0" d x 37.1" h	45.6" w x 23.4" d x 22.7" h	230 volts, 50 Hz no plug	Guardian 1000 Digital	280/127

* International electrical configuration

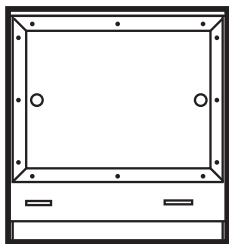

TOP

	2-Foot	3-Foot	4-Foot
A	24.0"	36.0"	48.0"
B	21.6"	33.6"	45.6"

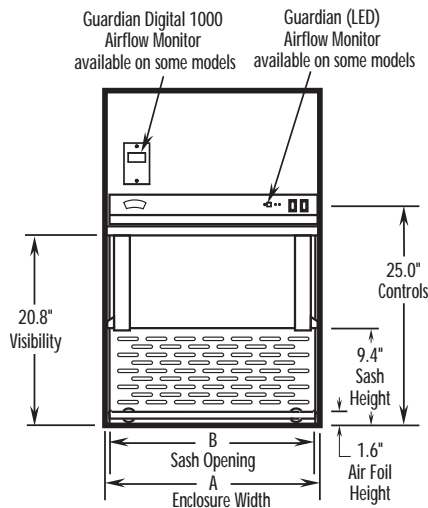

FRONT

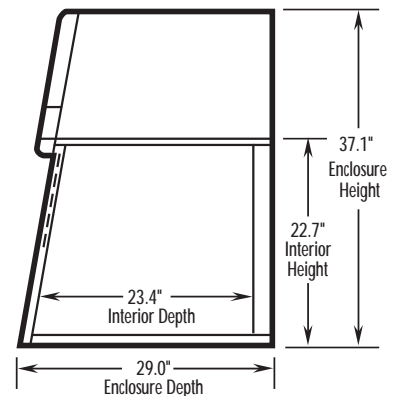

SIDE



XPert® Filtered Balance Systems

5' AND 6' MODELS ORDERING INFORMATION

XPert® Filtered Balance Systems							
Nominal Width	Catalog Number	Overall Dimensions	Interior Dimensions	Electrical Requirements	Built-In Airflow Monitor	Shipping Weight lbs./kg	
23.4" INTERIOR DEPTH	5'	3950500	60.0" w x 29.0" d x 46.3" h	57.6" w x 23.4" d x 32.0" h	115 volts, 60 Hz	None	500/227
	5'	3950501	60.0" w x 29.0" d x 46.3" h	57.6" w x 23.4" d x 32.0" h	115 volts, 60 Hz	Guardian	505/229
	5'	3950502	60.0" w x 29.0" d x 46.3" h	57.6" w x 23.4" d x 32.0" h	115 volts, 60 Hz	Guardian 1000 Digital	505/229
	5'	3950520*	60.0" w x 29.0" d x 46.3" h	57.6" w x 23.4" d x 32.0" h	230 volts, 50 Hz no plug	None	500/227
	5'	3950521*	60.0" w x 29.0" d x 46.3" h	57.6" w x 23.4" d x 32.0" h	230 volts, 50 Hz no plug	Guardian	505/229
	5'	3950522*	60.0" w x 29.0" d x 46.3" h	57.6" w x 23.4" d x 32.0" h	230 volts, 50 Hz no plug	Guardian 1000 Digital	505/229
30.0" INTERIOR DEPTH & INCLUDES WASTE CHUTE†	5'	3950530	60.0" [†] w x 35.5" d x 46.3" h	57.6" w x 30.0" d x 32.0" h	115 volts, 60 Hz	None	535/243
	5'	3950531	60.0" [†] w x 35.5" d x 46.3" h	57.6" w x 30.0" d x 32.0" h	115 volts, 60 Hz	Guardian	540/245
	5'	3950532	60.0" [†] w x 35.5" d x 46.3" h	57.6" w x 30.0" d x 32.0" h	115 volts, 60 Hz	Guardian 1000 Digital	540/245
	5'	3950540*	60.0" [†] w x 35.5" d x 46.3" h	57.6" w x 30.0" d x 32.0" h	230 volts, 50 Hz no plug	None	535/243
	5'	3950541*	60.0" [†] w x 35.5" d x 46.3" h	57.6" w x 30.0" d x 32.0" h	230 volts, 50 Hz no plug	Guardian	540/245
	5'	3950542*	60.0" [†] w x 35.5" d x 46.3" h	57.6" w x 30.0" d x 32.0" h	230 volts, 50 Hz no plug	Guardian 1000 Digital	540/245
23.4" INTERIOR DEPTH	6'	3950600	72.0" w x 29.0" d x 46.3" h	69.6" w x 23.4" d x 32.0" h	115 volts, 60 Hz	None	600/272
	6'	3950601	72.0" w x 29.0" d x 46.3" h	69.6" w x 23.4" d x 32.0" h	115 volts, 60 Hz	Guardian	605/274
	6'	3950602	72.0" w x 29.0" d x 46.3" h	69.6" w x 23.4" d x 32.0" h	115 volts, 60 Hz	Guardian 1000 Digital	605/274
	6'	3950620*	72.0" w x 29.0" d x 46.3" h	69.6" w x 23.4" d x 32.0" h	230 volts, 50 Hz no plug	None	600/272
	6'	3950621*	72.0" w x 29.0" d x 46.3" h	69.6" w x 23.4" d x 32.0" h	230 volts, 50 Hz no plug	Guardian	605/274
	6'	3950622*	72.0" w x 29.0" d x 46.3" h	69.6" w x 23.4" d x 32.0" h	230 volts, 50 Hz no plug	Guardian 1000 Digital	605/274
30.0" INTERIOR DEPTH & INCLUDES WASTE CHUTE†	6'	3950630	72.0" [†] w x 35.5" d x 46.3" h	69.6" w x 30.0" d x 32.0" h	115 volts, 60 Hz	None	640/290
	6'	3950631	72.0" [†] w x 35.5" d x 46.3" h	69.6" w x 30.0" d x 32.0" h	115 volts, 60 Hz	Guardian	645/293
	6'	3950632	72.0" [†] w x 35.5" d x 46.3" h	69.6" w x 30.0" d x 32.0" h	115 volts, 60 Hz	Guardian 1000 Digital	645/293
	6'	3950640*	72.0" [†] w x 35.5" d x 46.3" h	69.6" w x 30.0" d x 32.0" h	230 volts, 50 Hz no plug	None	640/290
	6'	3950641*	72.0" [†] w x 35.5" d x 46.3" h	69.6" w x 30.0" d x 32.0" h	230 volts, 50 Hz no plug	Guardian	645/293
	6'	3950642*	72.0" [†] w x 35.5" d x 46.3" h	69.6" w x 30.0" d x 32.0" h	230 volts, 50 Hz no plug	Guardian 1000 Digital	645/293

* International electrical configuration

† Width does not include waste chute. Waste chute adds 1.3" to overall width.



XPert® Filtered Balance Systems

5' AND 6' MODELS DIMENSIONAL DATA

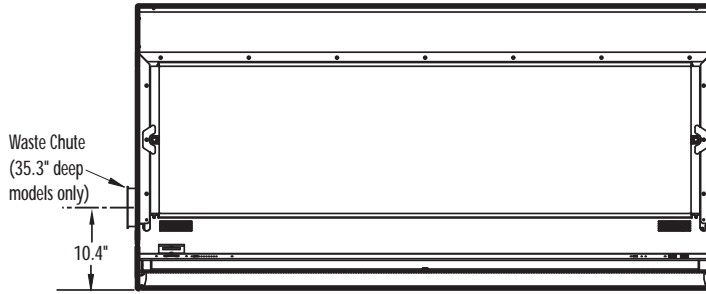

TOP

	5-Foot	6-Foot
A	60.0"	72.0"
B	57.6"	69.6"

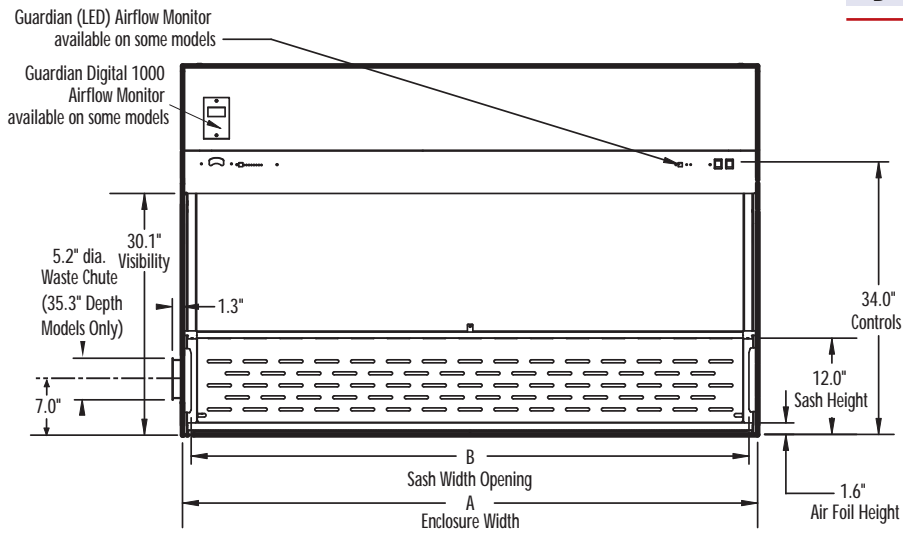

FRONT

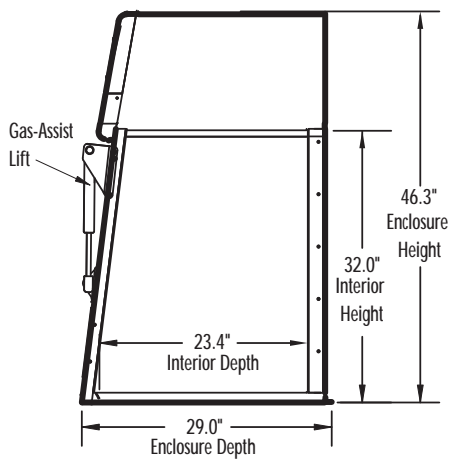

SIDE
(5', 6' MODELS, 29.0" DEEP)

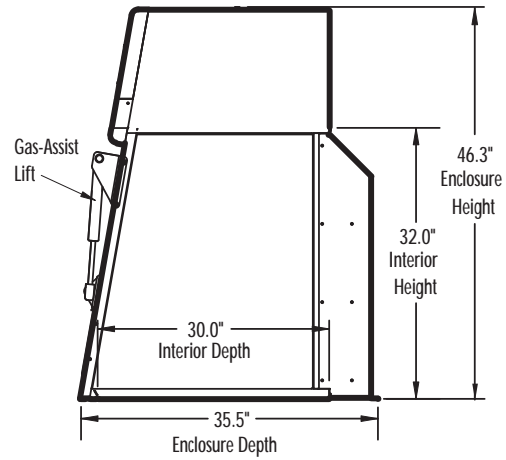

SIDE
(5', 6' MODELS, 35.5" DEEP)



Requires
Ductwork and
Blower



XPert® Filtered Balance Stations

FEATURES & BENEFITS

XPert Filtered Balance Stations are designed to protect the user during procedures involving powders and gases. The built-in HEPA filter, mounted in the upper plenum, removes particulates, so that clean air is exhausted to the atmosphere. As its name implies, **the XPert Filtered Balance Station is “stationary” because ducting to an outside blower is required.**

Powder weighing applications found in pharmaceutical research and other industries are typical for these enclosures. Like all enclosures in the XPert line, interior dimensions accommodate large micro and analytical balances and containment-enhancing features ensure personnel safety.

Front-mounted pressure gauge helps determine HEPA filter loading.

Exhaust collar allows connection to ductwork and remote blower.

Static-dissipative epoxy-coated aluminum frame and steel rear plenum and baffle. No unreliable plastic-to-plastic bonding is used.

Built-in airflow monitor alerts the user to face velocities outside of preset range. Models without monitor are also available.



Upper dilution air supply sweeps clean air to the back of sash to keep contaminants away from the operator. See page 3.

Ergonomic angled sash for comfortable viewing.

Tempered safety glass provides better fire, scratch and chemical resistance than acrylic and dissipates static charge.

Upper containment sash foil directs contaminants away from the user's breathing zone. See page 3.

Patented* Clean-Sweep™ air foil allows air to sweep the work surface to maximize containment. See page 3.

True bag-in/bag-out HEPA filter disposal system allows for safe replacement. See page 4.

Side-entry air foils allow air to sweep interior surfaces to enhance containment. See page 3.

Deep 23.4" interior easily accommodates large analytical balances. Some 5' and 6' models are available with 30" interior depths.



Patented* rear baffle with zones of perforations promotes horizontal laminar airflow. See page 4. The baffle pivots down for cleaning.

Optional left-side mounted waste chute isolates contaminated waste in a sealable bag. Some 5' and 6' models include a waste chute. Contact Labconco for ordering information on other models.



Exclusive feature
*U.S. Patent No. 6,461,233



XPert® Filtered Balance Stations

SPECIFICATIONS



XPert Filtered Balance Station 3940301 is shown with Black Solid Epoxy Dished Work Surface 3909902 and Protector Standard Storage Cabinets 9900300. Work surface, base cabinet, blower and ductwork must be ordered separately.



- Pre-wired fluorescent lamp and switches for remote blower and light. Blower switch is connected to an electrical relay and junction box behind the front panel.
- 1/4" thick tempered safety glass front sash and sides.
- Ergonomic angled and hinged, pivoting sash with wiping seal. Sashes on 5' and 6' models incorporate an external gas-assist lift.
- Models with 9.4" sash opening height have 16.5" locking height and 19.0" maximum loading height. Models with 12.0" sash opening height have 25.75" locking height and 28.25" maximum loading height.
- Two utility ports for pass-through of electrical cords.
- Particulate containment independently verified by SafeBridge Consultants, Inc.
- Validation package available at www.labconco.com containing balance stability, powder containment and modified ASHRAE 110-1995 Test Reports; Installation Qualification/Operation Qualification (IQ/OQ) Protocol; and Maintenance Log.
- Exhaust collar.

All models feature:

- Deep interior or 23.4" or 30.0" depending on the model.
- Ergonomic air foil with aerodynamic Clean-Sweep* airflow openings.
- Upper dilution air supply.
- Upper containment sash foil.
- Zone-perforated, pivoting rear baffle.*
- Side-entry air foils.
 - Exhaust HEPA filter, 99.99% efficient on particles 0.3 micron in size.
- Top-accessible HEPA filter for leak scanning of entire surface.
- True bag-in/bag-out filter disposal system (requires certified technician).
 - Pressure gauge.
 - Upper diffuser screen.
 - Glacier white and gray, dry powder epoxy-coated aluminum frame and steel rear plenum and baffle. No unreliable plastic-to-plastic bonding is used.

All models conform to the following regulations and standards:

- SEFA 1-2002
- Modified ASHRAE 110-1995
- ANSI Z9.5-1993
- UL 3101-1/61010-1
- CAN/CSA C22.2 No. 1010.1
- CE Conformity Marking (230 volt models)

Models with Guardian Airflow Monitor include:

- Guardian Airflow Monitor that continuously monitors airflow with a green LED that glows when airflow is within set point range and a red LED that glows and an audible alarm that sounds when airflow is outside set point range.

Models with Guardian 1000 Digital Airflow Monitor include:

- Guardian 1000 Digital Airflow Monitor that continuously monitors airflow and provides a digital readout of actual face velocity. An audible/visual alarm alerts the operator when airflow is outside set point range. RS232 communications port allows connection to user-supplied computer.

5' and 6' models with 35.5" exterior depth include:

- Left-side mounted waste chute. Bags not included. Minimum bag size required: 10" x 16".

All models require:

- Work surface. See page 41.
- Supporting base. See pages 39-40.
- Remote blower. See page 44.
- Ductwork. See pages 45-46.

Optional accessories for on-site installation include:

- Utility Shelves, Bottle Holder and Tissue Holder. See page 42.
- Waste Chute Bags. Contact your laboratory supply dealer.

Exclusive feature
*U.S. Patent No. 6,461,233

Nominal Width/Duct	Sash Opening Ht.	Total Exhaust CFM and Initial Static Pressure (w.g.)**					
		100 fpm	S.P.	80 fpm	S.P.	60 fpm	S.P.
2 Feet/6" dia.	9.4"	145	0.62"-0.72"	115	0.48"-0.57"	85	0.35"-0.41"
3 Feet/6" dia.	9.4"	220	0.68"-0.79"	175	0.53"-0.62"	130	0.37"-0.43"
4 Feet/6" dia.	9.4"	295	0.76"-0.87"	235	0.57"-0.66"	175	0.40"-0.46"
5 Feet/10" dia.	12.0"	480	0.72"-0.85"	385	0.55"-0.67"	290	0.38"-0.46"
6 Feet/10" dia.	12.0"	580	0.87"-1.03"	465	0.67"-0.81"	350	0.46"-0.56"

** Static pressure loss through HEPA filter gradually increases as filter loads.



XPert® Filtered Balance Stations

2', 3' AND 4' MODELS ORDERING INFORMATION & DIMENSIONAL DATA

XPert® Filtered Balance Stations						
Nominal Width	Catalog Number	Overall Dimensions	Interior Dimensions	Electrical Requirements	Built-In Airflow Monitor	Shipping Weight lbs./kg
2'	3940200	24.0" w x 29.0" d x 38.3" h	21.6" w x 23.4" d x 22.7" h	115 volts, 60 Hz	None	165/75
2'	3940201	24.0" w x 29.0" d x 38.3" h	21.6" w x 23.4" d x 22.7" h	115 volts, 60 Hz	Guardian	170/77
2'	3940202	24.0" w x 29.0" d x 38.3" h	21.6" w x 23.4" d x 22.7" h	115 volts, 60 Hz	Guardian 1000 Digital	170/77
2'	3940220*	24.0" w x 29.0" d x 38.3" h	21.6" w x 23.4" d x 22.7" h	230 volts, 50 Hz no plug	None	165/75
2'	3940221*	24.0" w x 29.0" d x 38.3" h	21.6" w x 23.4" d x 22.7" h	230 volts, 50 Hz no plug	Guardian	170/77
2'	3940222*	24.0" w x 29.0" d x 38.3" h	21.6" w x 23.4" d x 22.7" h	230 volts, 50 Hz no plug	Guardian 1000 Digital	170/77
3'	3940300	36.0" w x 29.0" d x 38.3" h	33.6" w x 23.4" d x 22.7" h	115 volts, 60 Hz	None	215/98
3'	3940301	36.0" w x 29.0" d x 38.3" h	33.6" w x 23.4" d x 22.7" h	115 volts, 60 Hz	Guardian	220/100
3'	3940302	36.0" w x 29.0" d x 38.3" h	33.6" w x 23.4" d x 22.7" h	115 volts, 60 Hz	Guardian 1000 Digital	220/100
3'	3940320*	36.0" w x 29.0" d x 38.3" h	33.6" w x 23.4" d x 22.7" h	230 volts, 50 Hz no plug	None	215/98
3'	3940321*	36.0" w x 29.0" d x 38.3" h	33.6" w x 23.4" d x 22.7" h	230 volts, 50 Hz no plug	Guardian	220/100
3'	3940322*	36.0" w x 29.0" d x 38.3" h	33.6" w x 23.4" d x 22.7" h	230 volts, 50 Hz no plug	Guardian 1000 Digital	220/100
4'	3940400	48.0" w x 29.0" d x 38.3" h	45.6" w x 23.4" d x 22.7" h	115 volts, 60 Hz	None	265/120
4'	3940401	48.0" w x 29.0" d x 38.3" h	45.6" w x 23.4" d x 22.7" h	115 volts, 60 Hz	Guardian	270/122
4'	3940402	48.0" w x 29.0" d x 38.3" h	45.6" w x 23.4" d x 22.7" h	115 volts, 60 Hz	Guardian 1000 Digital	270/122
4'	3940420*	48.0" w x 29.0" d x 38.3" h	45.6" w x 23.4" d x 22.7" h	230 volts, 50 Hz no plug	None	265/120
4'	3940421*	48.0" w x 29.0" d x 38.3" h	45.6" w x 23.4" d x 22.7" h	230 volts, 50 Hz no plug	Guardian	270/122
4'	3940422*	48.0" w x 29.0" d x 38.3" h	45.6" w x 23.4" d x 22.7" h	230 volts, 50 Hz no plug	Guardian 1000 Digital	270/122

* International electrical configuration

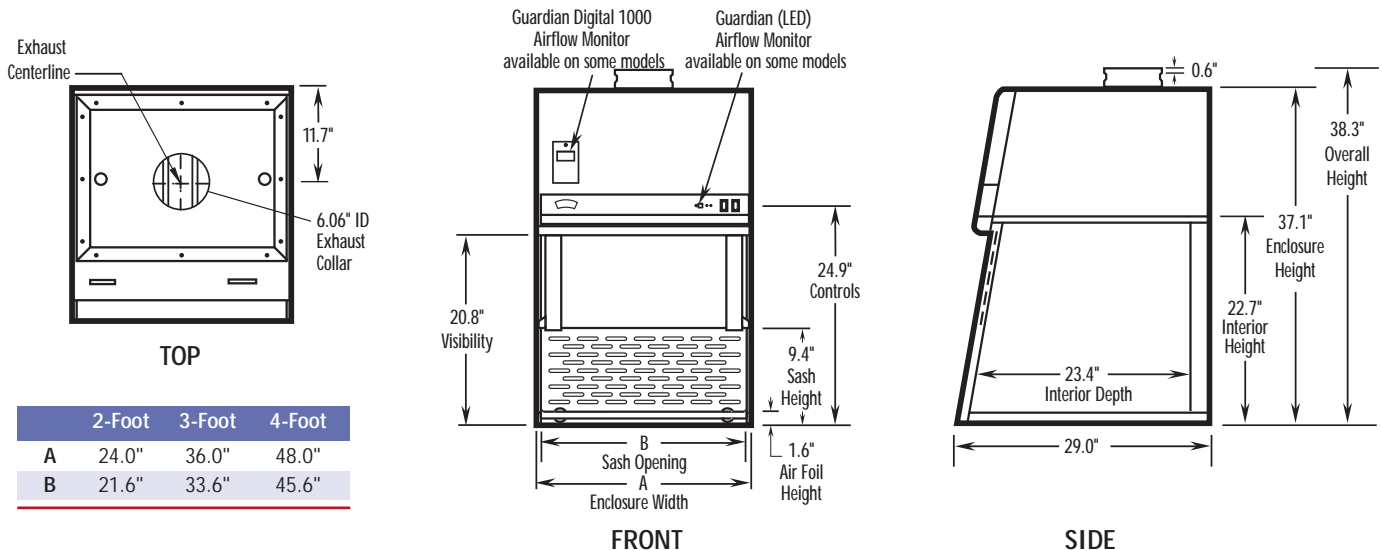



XPert® Filtered Balance Stations

5' AND 6' MODELS ORDERING INFORMATION

XPert® Filtered Balance Stations							
Nominal Width	Catalog Number	Overall Dimensions	Interior Dimensions	Electrical Requirements	Built-In Airflow Monitor	Shipping Weight lbs./kg	
23.4" INTERIOR DEPTH	5'	3946500	60.0" w x 29.0" d x 49.6" h	57.6" w x 23.4" d x 32.0" h	115 volts, 60 Hz	None	480/218
	5'	3946501	60.0" w x 29.0" d x 49.6" h	57.6" w x 23.4" d x 32.0" h	115 volts, 60 Hz	Guardian	485/220
	5'	3946502	60.0" w x 29.0" d x 49.6" h	57.6" w x 23.4" d x 32.0" h	115 volts, 60 Hz	Guardian 1000 Digital	485/220
	5'	3946520*	60.0" w x 29.0" d x 49.6" h	57.6" w x 23.4" d x 32.0" h	230 volts, 50 Hz no plug	None	480/218
	5'	3946521*	60.0" w x 29.0" d x 49.6" h	57.6" w x 23.4" d x 32.0" h	230 volts, 50 Hz no plug	Guardian	485/220
	5'	3946522*	60.0" w x 29.0" d x 49.6" h	57.6" w x 23.4" d x 32.0" h	230 volts, 50 Hz no plug	Guardian 1000 Digital	485/220
30.0" INTERIOR DEPTH & INCLUDES WASTE CHUTE†	5'	3946530	60.0"† w x 35.5" d x 49.6" h	57.6" w x 30.0" d x 32.0" h	115 volts, 60 Hz	None	515/234
	5'	3946531	60.0"† w x 35.5" d x 49.6" h	57.6" w x 30.0" d x 32.0" h	115 volts, 60 Hz	Guardian	520/236
	5'	3946532	60.0"† w x 35.5" d x 49.6" h	57.6" w x 30.0" d x 32.0" h	115 volts, 60 Hz	Guardian 1000 Digital	520/236
	5'	3946540*	60.0"† w x 35.5" d x 49.6" h	57.6" w x 30.0" d x 32.0" h	230 volts, 50 Hz no plug	None	515/234
	5'	3946541*	60.0"† w x 35.5" d x 49.6" h	57.6" w x 30.0" d x 32.0" h	230 volts, 50 Hz no plug	Guardian	520/236
	5'	3946542*	60.0"† w x 35.5" d x 49.6" h	57.6" w x 30.0" d x 32.0" h	230 volts, 50 Hz no plug	Guardian 1000 Digital	520/236
23.4" INTERIOR DEPTH	6'	3946600	72.0" w x 29.0" d x 49.6" h	69.6" w x 23.4" d x 32.0" h	115 volts, 60 Hz	None	580/263
	6'	3946601	72.0" w x 29.0" d x 49.6" h	69.6" w x 23.4" d x 32.0" h	115 volts, 60 Hz	Guardian	585/265
	6'	3946602	72.0" w x 29.0" d x 49.6" h	69.6" w x 23.4" d x 32.0" h	115 volts, 60 Hz	Guardian 1000 Digital	585/265
	6'	3946620*	72.0" w x 29.0" d x 49.6" h	69.6" w x 23.4" d x 32.0" h	230 volts, 50 Hz no plug	None	580/263
	6'	3946621*	72.0" w x 29.0" d x 49.6" h	69.6" w x 23.4" d x 32.0" h	230 volts, 50 Hz no plug	Guardian	585/265
	6'	3946622*	72.0" w x 29.0" d x 49.6" h	69.6" w x 23.4" d x 32.0" h	230 volts, 50 Hz no plug	Guardian 1000 Digital	585/265
30.0" INTERIOR DEPTH & INCLUDES WASTE CHUTE†	6'	3946630	72.0"† w x 35.5" d x 49.6" h	69.6" w x 30.0" d x 32.0" h	115 volts, 60 Hz	None	620/281
	6'	3946631	72.0"† w x 35.5" d x 49.6" h	69.6" w x 30.0" d x 32.0" h	115 volts, 60 Hz	Guardian	625/283
	6'	3946632	72.0"† w x 35.5" d x 49.6" h	69.6" w x 30.0" d x 32.0" h	115 volts, 60 Hz	Guardian 1000 Digital	625/283
	6'	3946640*	72.0"† w x 35.5" d x 49.6" h	69.6" w x 30.0" d x 32.0" h	230 volts, 50 Hz no plug	None	620/281
	6'	3946641*	72.0"† w x 35.5" d x 49.6" h	69.6" w x 30.0" d x 32.0" h	230 volts, 50 Hz no plug	Guardian	625/283
	6'	3946642*	72.0"† w x 35.5" d x 49.6" h	69.6" w x 30.0" d x 32.0" h	230 volts, 50 Hz no plug	Guardian 1000 Digital	625/283

* International electrical configuration

† Width does not include waste chute. Waste chute adds 1.3" to overall width.



XPert® Filtered Balance Stations

5' AND 6' MODELS DIMENSIONAL DATA

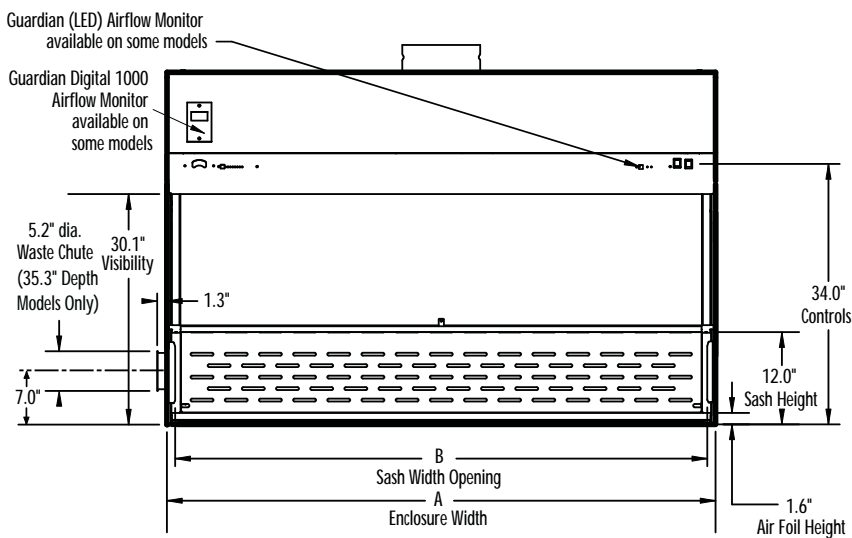
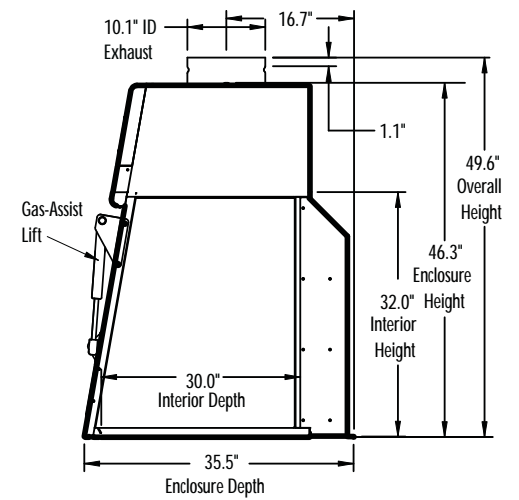
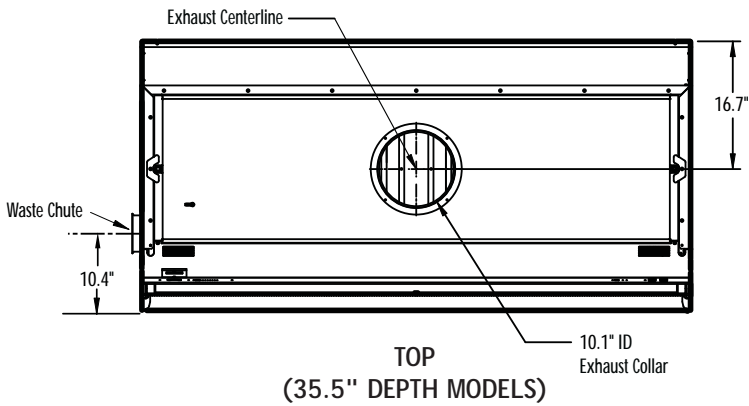
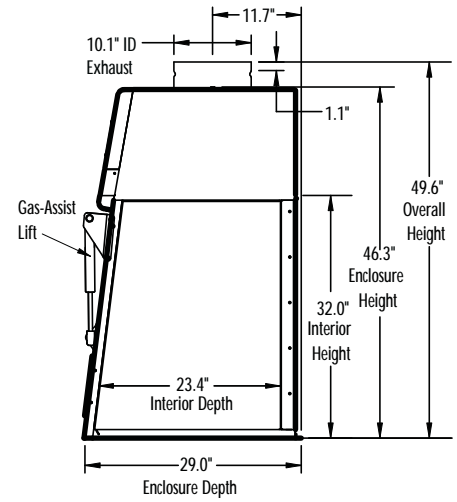
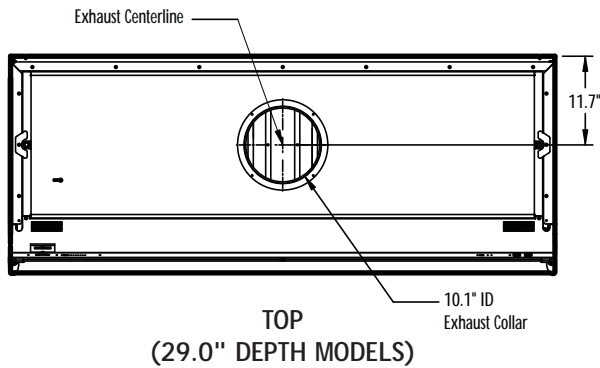

FRONT

**SIDE
(35.5" DEPTH MODELS)**

	5-Foot	6-Foot
A	60.0"	72.0"
B	57.6"	69.6"



Requires
Ductwork and
Blower



XPert® Balance Enclosures

FEATURES & BENEFITS

XPert Balance Enclosures provide user protection by keeping powders, particulates and fumes contained. Interior dimensions accommodate large micro and analytical balances. With their low profile, these enclosures exhaust less tempered room air than traditional fume hoods, conserving energy. They have no switches, wiring or service fixtures that can add significant costs.

XPert Balance Enclosures require venting. They may be connected to a remote blower and exhausted to the outside. When connected to the XPert Balance Enclosure, FilterMate Portable Exhausters provide an alternative to outside ducting. With a HEPA and/or carbon filter installed, the FilterMate rids the work area of hazardous particulates and/or fumes and vapors. No outside ducting is required.

Tempered safety glass front sash, sides and top offer excellent visibility, ambient light and protection. Glass provides better fire, scratch and chemical resistance than acrylic and dissipates static charge.

Flexible exhaust options. Exhaust openings at top and bottom permit connections to ductwork for outside exhausting or to a FilterMate™ Portable Exhauster. Using the bottom exhaust opening keeps ductwork hidden, maximizing room visibility.

Built-in airflow monitor alerts the user to face velocities outside of preset range. Models without monitor are also available.

Deep 23.4" interior easily accommodates large analytical balances. Some 5' and 6' models are available with 30" interior depths.

Upper dilution air supply sweeps clean air to the back of sash to keep contaminants away from the operator. See page 3.

Ergonomic angled sash for comfortable viewing.

Upper containment sash foil directs contaminants away from the user's breathing zone. See page 3.

Side-entry air foils allow air to sweep across the interior surfaces to enhance containment. See page 3.

8", 10" or 12" high sash opening limits exhaust demand, conserves costly tempered room air and requires a smaller remote blower than most fume hoods.

Static-dissipative epoxy-coated aluminum frame and steel rear plenum and baffle. No unreliable plastic-to-plastic bonding is used.

Patented* Clean-Sweep™ air foil allows air to sweep the work surface to maximize containment. See page 3.



Patented* rear baffle with zones of perforations promotes horizontal laminar airflow. See page 4. The baffle pivots down for cleaning.

Optional left-side mounted waste chute isolates contaminated waste in a sealable bag. Some 5', 6' and 8' models include a waste chute. Contact Labconco for ordering information on other models.

Exclusive feature
*U.S. Patent No. 6,461,233



XPert® Balance Enclosures

SPECIFICATIONS

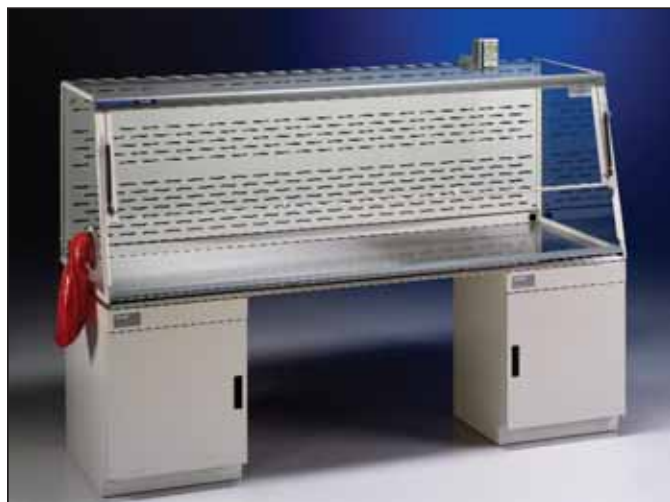

XPert Balance Enclosure 3971802 is shown with Stainless Steel Work Surface 3975800 and Protector Standard Storage Cabinets 9904300 and 9904000. Work Surface, base cabinets, blower and ductwork or FilterMate Portable Exhausters must be ordered separately.



All models feature:

- Deep interior of 23.4" or 30.0" depending on the model.
- Ergonomic air foil with aerodynamic Clean-Sweep* airflow openings.
- Upper dilution air supply.
- Upper containment sash foil.
- Zone-perforated, pivoting rear baffle.*
- Side-entry air foils.
- Glacier white and gray, dry powder epoxy-coated aluminum frame and steel rear plenum and baffle. No unreliable plastic-to-plastic bonding is used.
- 1/4" thick tempered safety glass front sash, sides and top.
 - Ergonomic 20° angled and hinged, pivoting sash with wiping seal. Sashes on 5', 6' and 8' models incorporate an external gas-assist lift.
 - Models with 8.0" sash opening height have 16.5" locking height and 19.0" maximum loading height. Models with 10.0" or 12.0" sash opening height have 25.75" locking height and 28.25" maximum loading height.
 - Two utility ports for pass-through of electrical cords.
- 2" x 10" rectangular exhaust openings at the top and bottom. 5', 6' and 8' models include three openings on the top and bottom. Cover(s) provided for unused openings.
- Particulate containment independently verified by SafeBridge Consultants, Inc.
- Modified ASHRAE 110-1995 conformity independently verified by ECT, Inc.
- Validation package available at www.labconco.com containing balance stability, powder containment and modified ASHRAE 110-1995. Test Reports;

Installation Qualification/Operation Qualification (IQ/OQ) Protocol; and Maintenance Log.

All models conform to the following regulations and standards:

- SEFA 1-2002
- Modified ASHRAE 110-1995
- ANSI Z9.5-1993

Models with Guardian 500 Airflow Monitor include:

- Guardian 500 Airflow Monitor that continuously monitors airflow with a green LED that glows when airflow is within set point range and a red LED that glows and an audible alarm that sounds when airflow is outside set point range. Includes epoxy-coated steel housing for mounting.

Exclusive feature *U.S. Patent No. 6,461,233

Models with Guardian 1000 Digital Airflow Monitor include:

- Guardian 1000 Digital Airflow Monitor that continuously monitors airflow and provides a digital readout of actual face velocity. An audible/visual alarm alerts the operator when airflow is outside set point range. RS232 communications port allows connection to user-supplied computer and may be configured for external input connections such as night setback or external alarm and up to three output relays. Includes epoxy-coated steel housing for mounting.

5', 6' and 8' models with 35.5" exterior depth include:

- Left-side mounted waste chute. Bags not included. Minimum bag size required: 10" x 16".

All models require:

- FilterMate Portable Exhauster(s) or remote blower (each sold separately). See pages 36-37 and 44.
- Work surface. See page 41.
- Supporting base. See pages 39-40.
- Ductwork. See pages 45-46 and inside back cover.

Optional accessories for on-site installation include:

- Fluorescent Lights. See page 42.
- Utility Shelves, Bottle Holder and Tissue Holder. See page 42.
- Transition Adapters. See page 43.
- Waste Chute Bags. Contact your laboratory supply dealer.

Nominal Width	Height	Sash Opening Ht.	Total Exhaust CFM and Static Pressure (w.g.)					
			100 fpm	S.P.	80 fpm	S.P.	60 fpm	S.P.
2 Feet	Std.	8"	120	0.05"	95	0.03"	70	0.02"
2 Feet	Tall	10"	150	0.08"	120	0.05"	90	0.03"
3 Feet	Std.	8"	185	0.10"	145	0.06"	110	0.04"
3 Feet	Tall	10"	230	0.15"	185	0.10"	140	0.06"
4 Feet	Std.	8"	250	0.16"	200	0.10"	150	0.06"
4 Feet	Tall	10"	310	0.24"	250	0.16"	185	0.09"
5 Feet	Std.	8"	315	0.23"	250	0.15"***	190	0.08"
5 Feet	Tall	12"	480	0.54"	385	0.35"***	290	0.20"
6 Feet	Std.	8"	380	0.32"	305	0.21"***	230	0.12"
6 Feet	Tall	12"	580	0.75"	465	0.48"***	350	0.27"
8 Feet	Std.	8"	510	0.18"	410	0.12"†	310	0.07"
8 Feet	Tall	12"	775	0.42"	620	0.27"†	465	0.15"

** Static pressure when one center exhaust opening is used.

† Static pressure when two outer exhaust openings are used. Requires "T" Connector 3981600, not included. Contact Labconco.



XPert® Balance Enclosures

2', 3' AND 4' MODELS ORDERING INFORMATION

XPert® Balance Enclosures								
	Nominal Width	Catalog Number	Enclosure Height	Overall Dimensions	Interior Dimensions	Electrical Requirements	Built-In Airflow Monitor	Shipping Wt. lbs./kg
STANDARD	2'	3930200	22.8"	24.0" w x 29.0" d x 22.8" h	22.8" w x 23.4" d x 22.3" h	—	None	105/48
	2'	3930201	22.8"	24.0" w x 29.0" d x 28.6" h	22.8" w x 23.4" d x 22.3" h	115 volts, 60 Hz	Guardian 500	110/50
	2'	3930202	22.8"	24.0" w x 29.0" d x 28.6" h	22.8" w x 23.4" d x 22.3" h	115 volts, 60 Hz	Guardian 1000 Digital	110/50
	2'	3930221*	22.8"	24.0" w x 29.0" d x 28.6" h	22.8" w x 23.4" d x 22.3" h	230 volts, 50 Hz	Guardian 500	110/50
	2'	3930222*	22.8"	24.0" w x 29.0" d x 28.6" h	22.8" w x 23.4" d x 22.3" h	230 volts, 50 Hz	Guardian 1000 Digital	110/50
TALL	2'	3930230	32.0"	24.0" w x 29.0" d x 32.0" h	22.8" w x 23.4" d x 31.5" h	—	None	135/61
	2'	3930231	32.0"	24.0" w x 29.0" d x 37.8" h	22.8" w x 23.4" d x 31.5" h	115 volts, 60 Hz	Guardian 500	140/64
	2'	3930232	32.0"	24.0" w x 29.0" d x 37.8" h	22.8" w x 23.4" d x 31.5" h	115 volts, 60 Hz	Guardian 1000 Digital	140/64
	2'	3930241*	32.0"	24.0" w x 29.0" d x 37.8" h	22.8" w x 23.4" d x 31.5" h	230 volts, 50 Hz	Guardian 500	140/64
	2'	3930242*	32.0"	24.0" w x 29.0" d x 37.8" h	22.8" w x 23.4" d x 31.5" h	230 volts, 50 Hz	Guardian 1000 Digital	140/64
STANDARD	3'	3930300	22.8"	36.0" w x 29.0" d x 22.8" h	34.8" w x 23.4" d x 22.3" h	—	None	135/61
	3'	3930301	22.8"	36.0" w x 29.0" d x 28.6" h	34.8" w x 23.4" d x 22.3" h	115 volts, 60 Hz	Guardian 500	140/64
	3'	3930302	22.8"	36.0" w x 29.0" d x 28.6" h	34.8" w x 23.4" d x 22.3" h	115 volts, 60 Hz	Guardian 1000 Digital	140/64
	3'	3930321*	22.8"	36.0" w x 29.0" d x 28.6" h	34.8" w x 23.4" d x 22.3" h	230 volts, 50 Hz	Guardian 500	140/64
	3'	3930322*	22.8"	36.0" w x 29.0" d x 28.6" h	34.8" w x 23.4" d x 22.3" h	230 volts, 50 Hz	Guardian 1000 Digital	140/64
TALL	3'	3930330	32.0"	36.0" w x 29.0" d x 32.0" h	34.8" w x 23.4" d x 31.5" h	—	None	160/73
	3'	3930331	32.0"	36.0" w x 29.0" d x 37.8" h	34.8" w x 23.4" d x 31.5" h	115 volts, 60 Hz	Guardian 500	165/75
	3'	3930332	32.0"	36.0" w x 29.0" d x 37.8" h	34.8" w x 23.4" d x 31.5" h	115 volts, 60 Hz	Guardian 1000 Digital	165/75
	3'	3930341*	32.0"	36.0" w x 29.0" d x 37.8" h	34.8" w x 23.4" d x 31.5" h	230 volts, 50 Hz	Guardian 500	165/75
	3'	3930342*	32.0"	36.0" w x 29.0" d x 37.8" h	34.8" w x 23.4" d x 31.5" h	230 volts, 50 Hz	Guardian 1000 Digital	165/75
STANDARD	4'	3930400	22.8"	48.0" w x 29.0" d x 22.8" h	46.8" w x 23.4" d x 22.3" h	—	None	160/73
	4'	3930401	22.8"	48.0" w x 29.0" d x 28.6" h	46.8" w x 23.4" d x 22.3" h	115 volts, 60 Hz	Guardian 500	165/75
	4'	3930402	22.8"	48.0" w x 29.0" d x 28.6" h	46.8" w x 23.4" d x 22.3" h	115 volts, 60 Hz	Guardian 1000 Digital	165/75
	4'	3930421*	22.8"	48.0" w x 29.0" d x 28.6" h	46.8" w x 23.4" d x 22.3" h	230 volts, 50 Hz	Guardian 500	165/75
	4'	3930422*	22.8"	48.0" w x 29.0" d x 28.6" h	46.8" w x 23.4" d x 22.3" h	230 volts, 50 Hz	Guardian 1000 Digital	165/75
TALL	4'	3930430	32.0"	48.0" w x 29.0" d x 32.0" h	46.8" w x 23.4" d x 31.5" h	—	None	185/84
	4'	3930431	32.0"	48.0" w x 29.0" d x 37.8" h	46.8" w x 23.4" d x 31.5" h	115 volts, 60 Hz	Guardian 500	190/86
	4'	3930432	32.0"	48.0" w x 29.0" d x 37.8" h	46.8" w x 23.4" d x 31.5" h	115 volts, 60 Hz	Guardian 1000 Digital	190/86
	4'	3930441*	32.0"	48.0" w x 29.0" d x 37.8" h	46.8" w x 23.4" d x 31.5" h	230 volts, 50 Hz	Guardian 500	190/86
	4'	3930442*	32.0"	48.0" w x 29.0" d x 37.8" h	46.8" w x 23.4" d x 31.5" h	230 volts, 50 Hz	Guardian 1000 Digital	190/86

*International electrical configuration



XPert Filtered Balance Enclosure 3930302 is shown with Black Solid Epoxy Work Surface 3908401 and Protector Standard Storage Cabinet 9900100. Work Surface, base cabinet, blower and ductwork or FilterMate Portable Exhauster must be ordered separately.



Requires Ductwork and Blower



XPert® Balance Enclosures

5', 6' AND 8' MODELS ORDERING INFORMATION

XPert® Balance Enclosures								
	Nominal Width	Catalog Number	Enclosure Height	Overall Dimensions	Interior Dimensions	Electrical Requirements	Built-In Airflow Monitor	Shipping Wt. lbs./kg
STANDARD	5'	3971500	22.8"	60.0" w x 29.0" d x 22.8" h	58.8" w x 23.4" d x 22.3" h	—	None	290/132
	5'	3971501	22.8"	60.0" w x 29.0" d x 28.6" h	58.8" w x 23.4" d x 22.3" h	115 volts, 60 Hz	Guardian 500	295/134
	5'	3971502	22.8"	60.0" w x 29.0" d x 28.6" h	58.8" w x 23.4" d x 22.3" h	115 volts, 60 Hz	Guardian 1000 Digital	295/134
	5'	3971521*	22.8"	60.0" w x 29.0" d x 28.6" h	58.8" w x 23.4" d x 22.3" h	230 volts, 50 Hz	Guardian 500	295/134
	5'	3971522*	22.8"	60.0" w x 29.0" d x 28.6" h	58.8" w x 23.4" d x 22.3" h	230 volts, 50 Hz	Guardian 1000 Digital	295/134
TALL	5'	3971530	32.0"	60.0" w x 29.0" d x 32.0" h	58.8" w x 23.4" d x 31.5" h	—	None	340/154
	5'	3971531	32.0"	60.0" w x 29.0" d x 37.8" h	58.8" w x 23.4" d x 31.5" h	115 volts, 60 Hz	Guardian 500	345/156
	5'	3971532	32.0"	60.0" w x 29.0" d x 37.8" h	58.8" w x 23.4" d x 31.5" h	115 volts, 60 Hz	Guardian 1000 Digital	345/156
	5'	3971541*	32.0"	60.0" w x 29.0" d x 37.8" h	58.8" w x 23.4" d x 31.5" h	230 volts, 50 Hz	Guardian 500	345/156
	5'	3971542*	32.0"	60.0" w x 29.0" d x 37.8" h	58.8" w x 23.4" d x 31.5" h	230 volts, 50 Hz	Guardian 1000 Digital	345/156
TALL & DEEP w/WASTE CHUTE†	5'	3971560	32.0"	60.0" w x 35.5" d x 32.0" h	58.8" w x 30.0" d x 31.5" h	—	None	380/172
	5'	3971561	32.0"	60.0" w x 35.5" d x 37.8" h	58.8" w x 30.0" d x 31.5" h	115 volts, 60 Hz	Guardian 500	385/175
	5'	3971562	32.0"	60.0" w x 35.5" d x 37.8" h	58.8" w x 30.0" d x 31.5" h	115 volts, 60 Hz	Guardian 1000 Digital	385/175
	5'	3971571*	32.0"	60.0" w x 35.5" d x 37.8" h	58.8" w x 30.0" d x 31.5" h	230 volts, 50 Hz	Guardian 500	385/175
	5'	3971572*	32.0"	60.0" w x 35.5" d x 37.8" h	58.8" w x 30.0" d x 31.5" h	230 volts, 50 Hz	Guardian 1000 Digital	385/175
STANDARD	6'	3971600	22.8"	72.0" w x 29.0" d x 22.8" h	70.8" w x 23.4" d x 22.3" h	—	None	340/154
	6'	3971601	22.8"	72.0" w x 29.0" d x 28.6" h	70.8" w x 23.4" d x 22.3" h	115 volts, 60 Hz	Guardian 500	345/156
	6'	3971602	22.8"	72.0" w x 29.0" d x 28.6" h	70.8" w x 23.4" d x 22.3" h	115 volts, 60 Hz	Guardian 1000 Digital	345/156
	6'	3971621*	22.8"	72.0" w x 29.0" d x 28.6" h	70.8" w x 23.4" d x 22.3" h	230 volts, 50 Hz	Guardian 500	345/156
	6'	3971622*	22.8"	72.0" w x 29.0" d x 28.6" h	70.8" w x 23.4" d x 22.3" h	230 volts, 50 Hz	Guardian 1000 Digital	345/156
TALL	6'	3971630	32.0"	72.0" w x 29.0" d x 32.0" h	70.8" w x 23.4" d x 31.5" h	—	None	395/179
	6'	3971631	32.0"	72.0" w x 29.0" d x 37.8" h	70.8" w x 23.4" d x 31.5" h	115 volts, 60 Hz	Guardian 500	400/181
	6'	3971632	32.0"	72.0" w x 29.0" d x 37.8" h	70.8" w x 23.4" d x 31.5" h	115 volts, 60 Hz	Guardian 1000 Digital	400/181
	6'	3971641*	32.0"	72.0" w x 29.0" d x 37.8" h	70.8" w x 23.4" d x 31.5" h	230 volts, 50 Hz	Guardian 500	400/181
	6'	3971642*	32.0"	72.0" w x 29.0" d x 37.8" h	70.8" w x 23.4" d x 31.5" h	230 volts, 50 Hz	Guardian 1000 Digital	400/181
TALL & DEEP w/WASTE CHUTE†	6'	3971660	32.0"	72.0" w x 35.5" d x 32.0" h	70.8" w x 30.0" d x 31.5" h	—	None	440/200
	6'	3971661	32.0"	72.0" w x 35.5" d x 37.8" h	70.8" w x 30.0" d x 31.5" h	115 volts, 60 Hz	Guardian 500	445/202
	6'	3971662	32.0"	72.0" w x 35.5" d x 37.8" h	70.8" w x 30.0" d x 31.5" h	115 volts, 60 Hz	Guardian 1000 Digital	445/202
	6'	3971671*	32.0"	72.0" w x 35.5" d x 37.8" h	70.8" w x 30.0" d x 31.5" h	230 volts, 50 Hz	Guardian 500	445/202
	6'	3971672*	32.0"	72.0" w x 35.5" d x 37.8" h	70.8" w x 30.0" d x 31.5" h	230 volts, 50 Hz	Guardian 1000 Digital	445/202
STANDARD	8'	3971800	22.8"	96.0" w x 29.0" d x 22.8" h	94.8" w x 23.4" d x 22.3" h	—	None	455/206
	8'	3971801	22.8"	96.0" w x 29.0" d x 28.6" h	94.8" w x 23.4" d x 22.3" h	115 volts, 60 Hz	Guardian 500	460/209
	8'	3971802	22.8"	96.0" w x 29.0" d x 28.6" h	94.8" w x 23.4" d x 22.3" h	115 volts, 60 Hz	Guardian 1000 Digital	460/209
	8'	3971821*	22.8"	96.0" w x 29.0" d x 28.6" h	94.8" w x 23.4" d x 22.3" h	230 volts, 50 Hz	Guardian 500	460/209
	8'	3971822*	22.8"	96.0" w x 29.0" d x 28.6" h	94.8" w x 23.4" d x 22.3" h	230 volts, 50 Hz	Guardian 1000 Digital	460/209
TALL	8'	3971830	32.0"	96.0" w x 29.0" d x 32.0" h	94.8" w x 23.4" d x 31.5" h	—	None	520/236
	8'	3971831	32.0"	96.0" w x 29.0" d x 37.8" h	94.8" w x 23.4" d x 31.5" h	115 volts, 60 Hz	Guardian 500	525/238
	8'	3971832	32.0"	96.0" w x 29.0" d x 37.8" h	94.8" w x 23.4" d x 31.5" h	115 volts, 60 Hz	Guardian 1000 Digital	525/238
	8'	3971841*	32.0"	96.0" w x 29.0" d x 37.8" h	94.8" w x 23.4" d x 31.5" h	230 volts, 50 Hz	Guardian 500	525/238
	8'	3971842*	32.0"	96.0" w x 29.0" d x 37.8" h	94.8" w x 23.4" d x 31.5" h	230 volts, 50 Hz	Guardian 1000 Digital	525/238
TALL & DEEP w/WASTE CHUTE†	8'	3971860	32.0"	96.0" w x 35.5" d x 32.0" h	94.8" w x 30.0" d x 31.5" h	—	None	580/263
	8'	3971861	32.0"	96.0" w x 35.5" d x 37.8" h	94.8" w x 30.0" d x 31.5" h	115 volts, 60 Hz	Guardian 500	580/263
	8'	3971862	32.0"	96.0" w x 35.5" d x 37.8" h	94.8" w x 30.0" d x 31.5" h	115 volts, 60 Hz	Guardian 1000 Digital	580/263
	8'	3971871*	32.0"	96.0" w x 35.5" d x 37.8" h	94.8" w x 30.0" d x 31.5" h	230 volts, 50 Hz	Guardian 500	580/263
	8'	3971872*	32.0"	96.0" w x 35.5" d x 37.8" h	94.8" w x 30.0" d x 31.5" h	230 volts, 50 Hz	Guardian 1000 Digital	580/263

*International electrical configuration

†Width does not include waste chute. Waste chute adds 1.3" to overall width.



XPert® Balance Enclosures

DIMENSIONAL DATA

	2-Foot Std Ht	2-Foot Tall	3-Foot Std Ht	3-Foot Tall	4-Foot Std Ht	4-Foot Tall	5-Foot Std Ht	5-Foot Tall	5-Foot Tall & Deep	6-Foot Std Ht	6-Foot Tall	6-Foot Tall & Deep	8-Foot Std Ht	8-Foot Tall	8-Foot Tall & Deep
A	24.0"	24.0"	36.0"	36.0"	48.0"	48.0"	60.0"	60.0"	60.0"	72.0"	72.0"	72.0"	96.0"	96.0"	96.0"
B	12.0"	12.0"	18.0"	18.0"	24.0"	24.0"	30.0"	30.0"	30.0"	36.0"	36.0"	36.0"	48.0"	48.0"	48.0"
C	21.6"	21.6"	33.6"	33.6"	45.6"	45.6"	57.6"	57.6"	57.6"	69.6"	69.6"	69.6"	93.6"	93.6"	93.6"
D	28.6"	37.8"	28.6"	37.8"	28.6"	37.8"	28.6"	37.8"	37.8"	28.6"	37.8"	37.8"	28.6"	37.8"	37.8"
E	22.8"	32.0"	22.8"	32.0"	22.8"	32.0"	22.8"	32.0"	32.0"	22.8"	32.0"	32.0"	22.8"	32.0"	32.0"
F	22.3"	31.5"	22.3"	31.5"	22.3"	31.5"	22.3"	31.5"	31.5"	22.3"	31.5"	31.5"	22.3"	31.3"	31.3"
G	19.0"	27.7"	19.0"	27.7"	19.0"	27.7"	19.0"	27.7"	27.7"	19.0"	27.7"	27.7"	19.0"	27.7"	27.7"
H	29.0"	29.0"	29.0"	29.0"	29.0"	29.0"	29.0"	29.0"	35.5"	29.0"	29.0"	35.5"	29.0"	29.0"	35.5"
I	23.4"	23.4"	23.4"	23.4"	23.4"	23.4"	23.4"	23.4"	30.0"	23.4"	23.4"	30.0"	23.4"	23.4"	30.0"
J	8.0"	10.0"	8.0"	10.0"	8.0"	10.0"	8.0"	12.0"	12.0"	8.0"	12.0"	12.0"	8.0"	12.0"	12.0"
K	—	—	—	—	—	—	10.0"	10.0"	10.0"	10.0"	10.0"	10.0"	24.0"	24.0"	24.0"

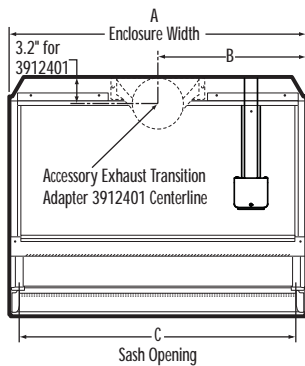

TOP (2', 3', 4' MODELS)

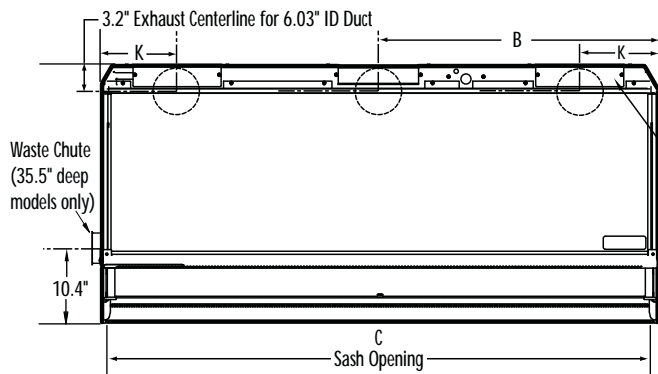

TOP (5', 6', 8' MODELS)

5' and 6' enclosures include five covers, two on top and three on the bottom. 8' enclosures include four covers, one on top and three on the bottom.

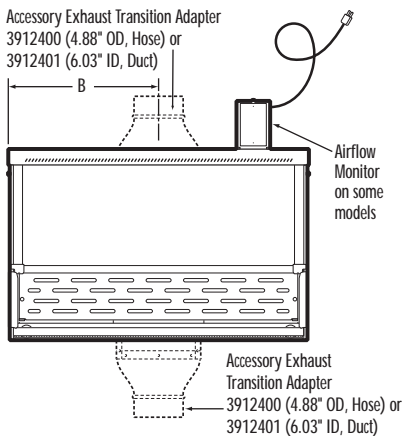

FRONT (2', 3', 4' MODELS)

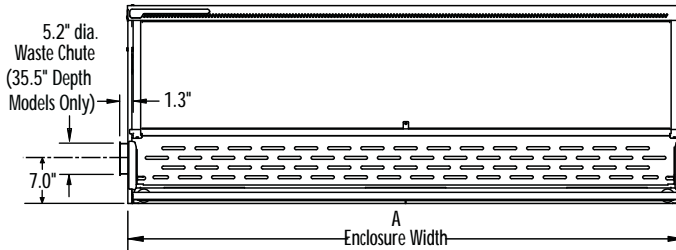

FRONT (5', 6', 8' MODELS. AIRFLOW MONITOR AND EXHAUST TRANSITION ADAPTERS NOT SHOWN.)

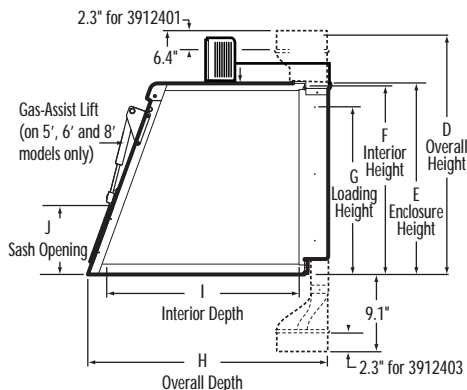

SIDE (ALL MODELS)



XPert® Easy-Order SPECIFICATIONS











XPert Easy-Order 3960302 is shown with Protector Standard Storage Cabinet 9900100. Base Cabinet must be ordered separately.



All models include:

- XPert Balance Enclosure
- FilterMate Portable Exhauster 3970000
- Black Solid Epoxy Dished Work Surface

Features of the XPert Balance Enclosure:

-  Deep 23.4" interior.
-  Ergonomic air foil with aerodynamic Clean-Sweep* airflow openings.
-  Upper containment sash foil.
-  Upper dilution air supply.
-  Zone-perforated, pivoting rear baffle.*
-  Side-entry air foils.
-  Glacier white and gray, dry powder epoxy-coated aluminum frame and steel rear plenum and baffle. No unreliable plastic-to-plastic bonding is used.
-  Tempered safety glass front sash, sides and top.
 - Ergonomic 20° angled and hinged, pivoting sash with wiping seal.
 - 8.0" sash opening height, 16.5" locking height and 19.0" maximum loading height.
 - Two utility ports for pass-through of electrical cords.
-  2" x 10" rectangular exhaust openings at top and bottom. Cover provided for unused opening.
- Particulate containment independently verified by SafeBridge Consultants, Inc.

 Exclusive feature

 Exclusive feature

*U.S. Patent No. 6,461,233

- Modified ASHRAE 110-1995 conformity independently verified by ECT, Inc.
- Validation package available at www.labconco.com containing balance stability, powder containment, and modified ASHRAE 110-1995. Installation Qualification/Operation Qualification (IQ/OQ) Protocol; and Maintenance Log.

Models with Guardian 500 Airflow Monitor include:

- Guardian 500 Airflow Monitor that continuously monitors airflow with a green LED that glows when airflow is within set point range and a red LED that glows and an audible alarm that sounds when airflow is outside set point range. Includes epoxy-coated steel housing.





Models with Guardian 1000 Digital Airflow Monitor include:

- Guardian 1000 Digital Airflow Monitor that continuously monitors airflow and provides a digital readout of actual face velocity. An audible/visual alarm alerts the operator when airflow is outside set point range. RS232 communications port allows connection to user-supplied computer. Includes epoxy-coated steel housing.

Features of the FilterMate Portable Exhauster 3970000:

- Compact, corrosion-resistant housing of glacier white and light gray, dry powder epoxy-coated steel with vibration-isolated rubber feet.
- Variable-speed, non-sparking motorized impeller.
-  Quiet operation. Oversized HEPA filter, efficient impeller and perforated exhaust cover work together to provide lower system exhaust velocity and noise pressure levels.

Exhaust CFM	Noise Pressure dB(A)
100	45-47
150	51-54
200	56-61
250	63-65

-  Inherently safe design. A negative pressure plenum surrounds the positive pressure impeller so that if a leak occurs, the unfiltered air is captured and refiltered.
-  Capable of filtering up to 250 CFM for efficient HEPA filtration.
 - Front-mounted rocker switch to control power to the blower.
-  Rear-mounted, auxiliary electrical outlet that may be connected to an airflow monitor or other user-supplied accessories.
-  Provides up to 100 fpm face velocity for 2', 3' or 4' enclosure.
 - HEPA filter, 99.99% efficient on particulates 0.3 micron in size.
-  True bag-in/bag-out filter disposal system for safely removing and replacing the filter without detaching the hose. The HEPA filter may be easily accessed by removing the exhaust cover for field leak testing by a certified technician.
 - Included: 8 feet of 5" ID flexible, chemical-resistant polypropylene gray hose; two clamps and a 4.88" OD Upper Transition Adapter for connection to XPert Balance Enclosure or Protector XVS Ventilation Station.
 - IEC 3-wire electrical cord with plug.

All models conform to the following regulations and standards:

- SEFA 1-2002
- Modified ASHRAE 110-1995
- ANSI Z9.5-1993
- UL 3101-1/61010-1
- CAN/CSA C22.2 No. 1010.1

All models require:

- Supporting base. See pages 39-40.

Optional accessories for on-site installation include:

- Fluorescent Lights. See page 42.
- Utility Shelves, Bottle Holder and Tissue Holder. See page 42.
- Transition Adapters. See page 43.
- Manual Duct Dampers. See page 45.
- Replacement HEPA Filter. See page 38.
- Replacement Bag for Bag-In/Bag-Out HEPA Filter. See page 38.



XPert® Easy-Order

ORDERING INFORMATION

Nominal Width	Total Exhaust CFM and Initial Static Pressure (w.g.)*					
	100 fpm	S.P.	80 fpm	S.P.	60 fpm	S.P.
2 Feet	120	0.05"	95	0.03"	70	0.02"
3 Feet	185	0.10"	145	0.06"	110	0.04"
4 Feet	250	0.16"	200	0.10"	150	0.06"

* Static pressure loss through HEPA filter gradually increases as filter loads.

XPert Easy-Order (all include FilterMate Portable Exhauster with HEPA Filter #3970000)

Nominal Width**	Catalog Number	Includes	Electrical Requirements	Built-In Airflow Monitor	Shipping Weight lbs./kg
2'	3960201	2' XPert Enclosure #3930201, FilterMate #3970000, 2' Black Work Surface #3908400	115 volts, 60 Hz	Guardian 500	138/63
2'	3960202	2' XPert Enclosure #3930202, FilterMate #3970000, 2' Black Work Surface #3908400	115 volts, 60 Hz	Guardian 1000 Digital	138/63
3'	3960301	3' XPert Enclosure #3930301, FilterMate #3970000, 3' Black Work Surface #3908401	115 volts, 60 Hz	Guardian 500	182/83
3'	3960302	3' XPert Enclosure #3930302, FilterMate #3970000, 3' Black Work Surface #3908401	115 volts, 60 Hz	Guardian 1000 Digital	182/83
4'	3960401	4' XPert Enclosure #3930401, FilterMate #3970000, 4' Black Work Surface #3908402	115 volts, 60 Hz	Guardian 500	226/103
4'	3960402	4' XPert Enclosure #3930402, FilterMate #3970000, 4' Black Work Surface #3908402	115 volts, 60 Hz	Guardian 1000 Digital	226/103

** See Dimensional Data on XPert Balance Enclosures on page 25 and on FilterMate Portable Exhausters on pages 36-37.

XPert Easy-Order Components

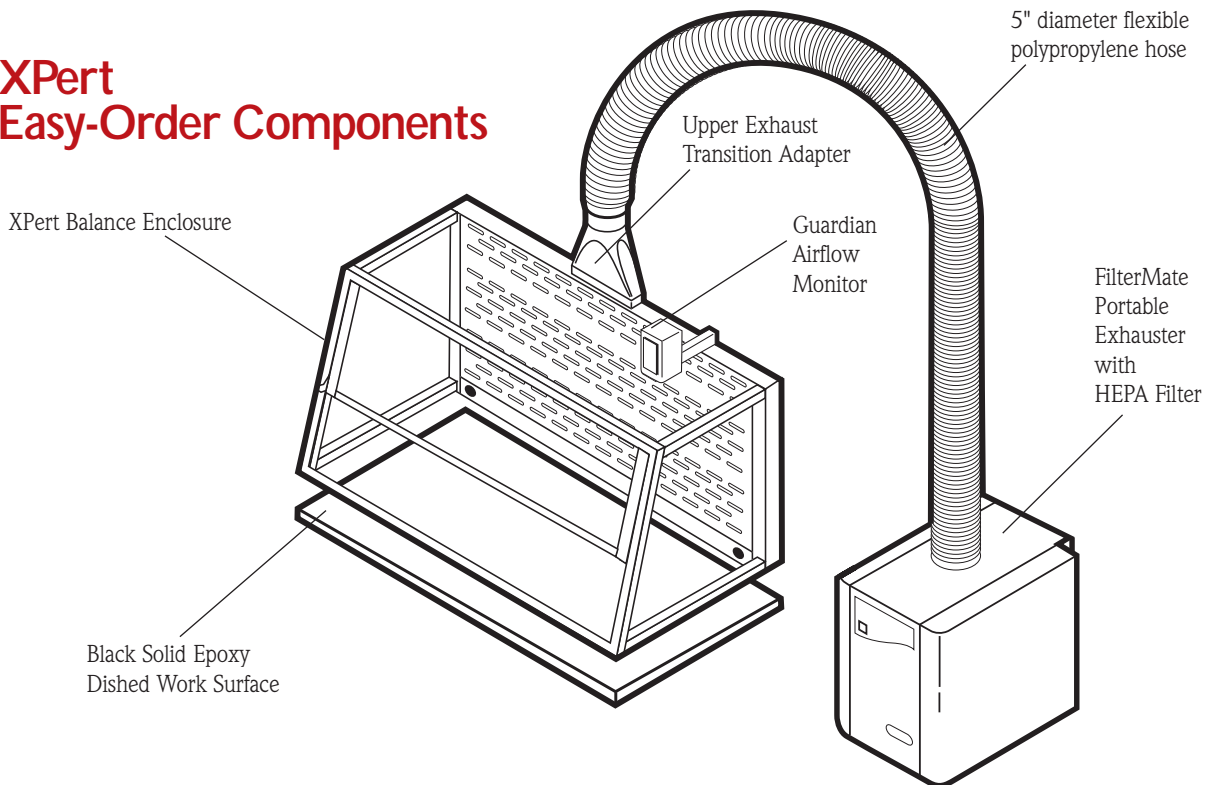



Requires
Ductwork and
Blower



XPert® Bulk Powder Filtered Systems, Filtered Stations & Enclosures

FEATURES & BENEFITS

XPert Bulk Powder Filtered Systems, Filtered Stations and Enclosures are designed to protect the user during powder transfer operations. Filtered Systems and Stations include a built-in HEPA filter, mounted in the upper plenum, that removes particulates in the exhaust air. XPert Filtered Systems include a built-in blower and do not require ducting to the outside. XPert Filtered

Stations have an exhaust collar and require ducting to house exhaust or a remote blower. XPert Bulk Powder Filtered Systems and Stations are available in 5' and 6' widths.

XPert Bulk Powder Enclosures require venting and may be connected to a remote blower or house exhaust and exhausted to the outside. These enclosures are available in 5', 6' and 8' widths.

Guardian 1000 digital monitor continuously monitors airflow and provides a digital readout of actual face velocity.

Front-mounted pressure gauge helps determine HEPA filter loading (Filtered Systems and Stations).

Stainless steel work surface has front trough to catch liquid spills.

Upper dilution air supply sweeps clean air to the back of sash to keep contaminants away from the operator. See page 3.

Tempered safety glass provides better fire, scratch and chemical resistance than acrylic and dissipates static charge.

Optimal HEPA filter location permits leak-detection scan of entire filter surface (Filtered Systems and Stations).

Side-entry air foils allow air to sweep interior surfaces to enhance containment. See page 3.

Push button-controlled electric hydraulic lift mechanism raises the container to the optimal ergonomic height. An electronic beam senses the location of the container and triggers the lift mechanism to automatically stop when the optimal height is reached.*

Transfer caddy is included. Caddy allows for easy transport of a source container to the enclosure's work area. It has a latch and positioning plate to ensure proper alignment with the work surface access opening.*



Patented* rear baffle with zones of perforations promotes horizontal laminar airflow. See page 4. The baffle pivots down for cleaning.

Exclusive feature * Patent pending



Optional left-side mounted waste chute isolates contaminated waste in a sealable bag.

True bag-in/bag-out HEPA filter disposal system allows for safe filter replacement (Filtered Systems and Stations). See page 4.

Base stand is included.



XPert® Bulk Powder Filtered Systems

SPECIFICATIONS



XPert Bulk Powder Filtered System 3961502 with Retaining Ring 3981300, Safety Sleeve 3981100 and Retaining Band 3981200.



All models feature:

- Ergonomic air foil with aerodynamic Clean-Sweep* airflow openings.
- Upper dilution air supply.
- Upper containment sash foil.
- Zone-perforated, pivoting rear baffle.*
 - Side-entry air foils.
 - Generous 30" interior depth and 32" interior height.
 - Exhaust HEPA filter, 99.99% efficient on particles 0.3 micron in size.
- Access to entire HEPA filter surface from top for filter leak scanning (by certified technician).
- True bag-in/bag-out filter disposal system (by certified technician).
 - Guardian 1000 Digital Airflow Monitor that continuously monitors airflow and provides a digital readout of actual face velocity. An audible/visual alarm alerts the operator when airflow is outside set point range. RS232 communications port allows connection to user-supplied computer and may be configured for external input connections such as night setback or external alarm and up to three output relays.
- Stainless steel work surface with front spill trough and right-side, center or left-side access opening for source container (drum).

- 2" square tubular steel base stand with leveling feet.
- Transfer caddy of glacier white, epoxy-coated 1" square tubular steel frame with 3" diameter caster that holds container up to 28" high x 19.5" dia. With caddy latch and positioning plate.**
- Push-button operated electric hydraulic lift mechanism for raising the container to the optimal ergonomic height (14" maximum travel distance).**
- Electronic beam to sense the location of the container and trigger the lift mechanism to automatically stop at the optimal access height.**
- Left side-mounted waste chute. Bags not included. Minimum bag size required: 10" x 16".
- Fourplex electrical receptacle located underneath the work surface.
- Intrinsically safe, negative pressure design.
- Pressure gauge.
- Space-saving design. No separate filtered exhauster is required.
- Upper diffuser screen.
- Quiet operation (see chart below).
- Glacier white and gray, dry powder epoxy-coated aluminum frame and steel rear plenum and baffle. No unreliable plastic-to-plastic bonding is used.
- Pre-wired fluorescent lamp and switches for blower and light.
- 1/4" thick tempered safety glass front sash and sides.
- Ergonomic angled and hinged, pivoting sash with wiping seal, external gas-assist lift, 12.0" sash opening height, 25.75" locking height and 28.25" maximum loading height.
- Two utility ports for pass-through of electrical cords.
- Shipped in two sections.
- No ducting is required. Filtered exhaust air is returned to the laboratory. Or System may be exhausted to the outside with the addition of the optional Canopy Connection.
- Particulate containment independently verified by SafeBridge Consultants, Inc.
- Validation package available at www.labconco.com with powder containment and modified ASHRAE 110-1995 Test Reports; Installation Qualification/Operation Qualification (IQ/OQ) Protocol; and Maintenance Log.

All models conform to the following regulations and standards:

- SEFA 1-2002
- Modified ASHRAE 110-1995
- ANSI Z9.5-1993
- UL 3101-1/61010-1
- CAN/CSA C22.2 No. 1010.1
- CE Conformity Marking (230 volt models)

All models require:

- Retaining Ring**+. See page 43.
- Safety Sleeves**. See page 43.
- Retaining Bands**. See page 43.
- Access Opening Cover. See page 43.
- Waste Chute Bags. Contact your laboratory supply dealer.

Optional accessories for on-site installation include:

- Additional Transfer Caddy. See page 43.
- Trace Odor Carbon Filters. See page 41.
- Utility Shelves, Bottle Holder and Tissue Holder. See page 42.
- Canopy Connections. See page 43.
- Remote Blowers. See page 44.
- Ductwork. See pages 45-46.

Exclusive feature

* U.S. Patent No. 6,461,233

** Patent pending

+ Ring selected should be a minimum of 2" smaller than source container's inner bag diameter.

Nominal Width	Total Exhaust CFM and Sound Levels					
	100 fpm	db(A)	80 fpm	db(A)	60 fpm	db(A)
5 Feet	480	63-67	385	58-63	290	52-56
6 Feet	580	67-69	465	61-63	350	55-57



XPert® Bulk Powder Filtered Systems

ORDERING INFORMATION & DIMENSIONAL DATA

XPert Bulk Powder Filtered Systems

Nominal Width	Catalog Number	Overall Dimensions	Interior Dimensions	Electrical Requirements	Access Opening Position	Combined Shipping Weight lbs./kg*
5'	3961500	60.0" w x 37.0" d x 83.0" h	57.6" w x 30.0" d x 32.0" h	115 volts, 60 Hz	Left Side	965/438
5'	3961501	60.0" w x 37.0" d x 83.0" h	57.6" w x 30.0" d x 32.0" h	115 volts, 60 Hz	Center	965/438
5'	3961502	60.0" w x 37.0" d x 83.0" h	57.6" w x 30.0" d x 32.0" h	115 volts, 60 Hz	Right Side	965/438
5'	3961520**	60.0" w x 37.0" d x 83.0" h	57.6" w x 30.0" d x 32.0" h	230 volts, 50 Hz	Left Side	965/438
5'	3961521**	60.0" w x 37.0" d x 83.0" h	57.6" w x 30.0" d x 32.0" h	230 volts, 50 Hz	Center	965/438
5'	3961522**	60.0" w x 37.0" d x 83.0" h	57.6" w x 30.0" d x 32.0" h	230 volts, 50 Hz	Right Side	965/438
6'	3961600	72.0" w x 37.0" d x 83.0" h	69.6" w x 30.0" d x 32.0" h	115 volts, 60 Hz	Left Side	1105/501
6'	3961601	72.0" w x 37.0" d x 83.0" h	69.6" w x 30.0" d x 32.0" h	115 volts, 60 Hz	Center	1105/501
6'	3961602	72.0" w x 37.0" d x 83.0" h	69.6" w x 30.0" d x 32.0" h	115 volts, 60 Hz	Right Side	1105/501
6'	3961620**	72.0" w x 37.0" d x 83.0" h	69.6" w x 30.0" d x 32.0" h	230 volts, 50 Hz	Left Side	1105/501
6'	3961621**	72.0" w x 37.0" d x 83.0" h	69.6" w x 30.0" d x 32.0" h	230 volts, 50 Hz	Center	1105/501
6'	3961622**	72.0" w x 37.0" d x 83.0" h	69.6" w x 30.0" d x 32.0" h	230 volts, 50 Hz	Right Side	1105/501

*Shipped in two sections. **International electrical configuration. No electrical plug included. † Width does not include waste chute. Waste chute adds 1.3" to overall width.

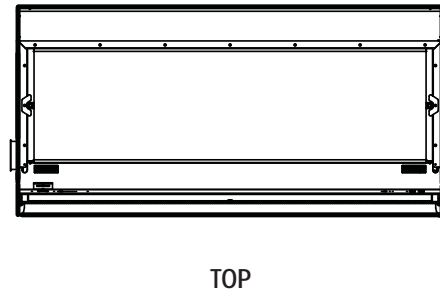
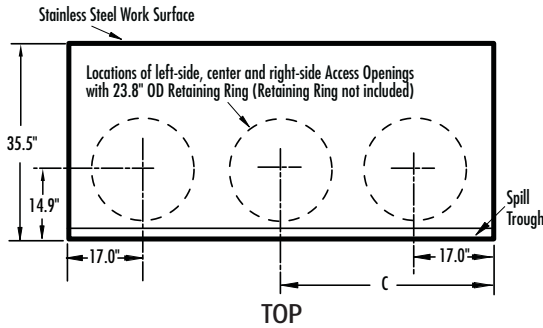

	5-Foot	6-Foot
A	60.0"	72.0"
B	57.6"	69.6"
C	30.0"	36.0"

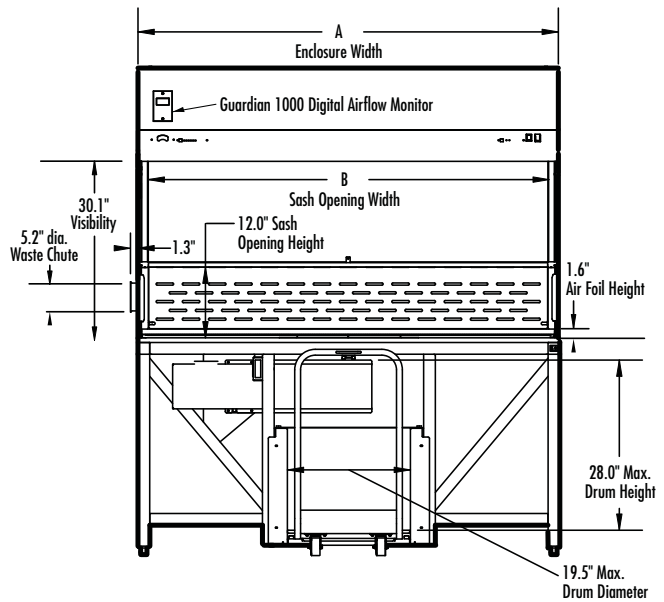
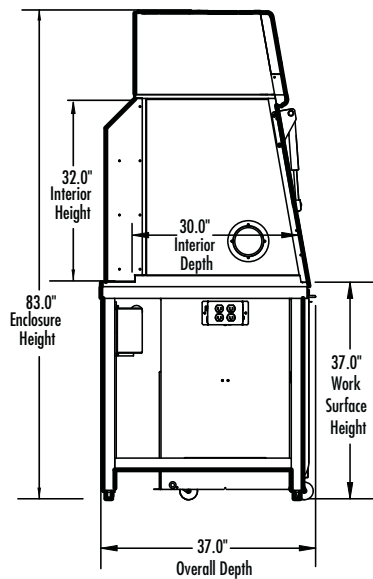

SIDE

FRONT



XPert® Bulk Powder Filtered Stations

SPECIFICATIONS



XPert Bulk Powder Filtered Station 3962502 with Retaining Ring 3981300, Safety Sleeve 3981100 and Retaining Band 3981200.



All models feature:

- Ergonomic air foil with aerodynamic Clean-Sweep* airflow openings.
- Upper dilution air supply.
- Upper containment sash foil.
- Zone-perforated, pivoting rear baffle.*
 - Side-entry air foils.
 - Generous 30" interior depth and 32" interior height.
 - Exhaust HEPA filter, 99.99% efficient on particles 0.3 micron in size.
- Access to entire HEPA filter surface from top for filter leak scanning (by certified technician).
- True bag-in/bag-out filter disposal system (by certified technician).
- Guardian 1000 Digital Airflow Monitor that continuously monitors airflow and provides a digital readout of actual face velocity. An audible/visual alarm alerts the operator when airflow is outside set point range. RS232 communications port allows connection to user-supplied computer and may be configured for external input connections such as night setback or external alarm and up to three output relays.
- Stainless steel work surface with front spill trough and right-side, center or left-side access opening for source container (drum).
- 2" square tubular steel base stand with leveling feet.

- Transfer caddy of glacier white, epoxy-coated 1" square tubular steel frame with 3" diameter caster that holds container up to 28" h x 19.5 dia. With caddy latch and positioning plate.**
- Push-button operated electric hydraulic lift mechanism for raising the container to the optimal ergonomic height.**
- Electronic beam to sense the location of the container and trigger the lift mechanism to automatically stop at the optimal access height (14" maximum travel distance).**
 - Left side-mounted waste chute. Bags not included. Minimum bag size required: 10" x 16".
 - Fourplex electrical receptacle located underneath the work surface.
 - Intrinsically safe, negative pressure design.
 - Pressure gauge.
 - Space-saving design. No separate filtered exhauster is required.
 - Upper diffuser screen.
 - Glacier white and gray, dry powder epoxy-coated aluminum frame and steel rear plenum and baffle. No unreliable plastic-to-plastic bonding is used.
 - Pre-wired fluorescent lamp and switches for remote blower and light.
 - 1/4" thick tempered safety glass front sash and sides.
 - Ergonomic angled and hinged, pivoting sash with wiping seal, external gas-assist lift, 12.0" sash opening height, 25.75" locking height and 28.25" maximum loading height.
 - Two utility ports for pass-through of electrical cords.
 - 10.19" OD, 10.09" ID duct collar. Requires ducting to house exhaust or a remote blower.

- Shipped in two sections.
- Validation package available at www.labconco.com with powder containment and modified ASHRAE 110-1995 Test Reports; Installation Qualification/Operation Qualification (IQ/OQ) Protocol; and Maintenance Log.

All models conform to the following regulations and standards:

- SEFA 1-2002
- Modified ASHRAE 110-1995
- ANSI Z9.5-1993
- UL 3101-1/61010-1
- CAN/CSA C22.2 No. 1010.1
- CE Conformity Marking (230 volt models)

All models require:

- Retaining Ring***. See page 43.
- Safety Sleeves**. See page 43.
- Retaining Bands**. See page 43.
- Access Opening Cover. See page 43.

- Remote Blower. See page 44.
- Ductwork. See pages 45-46.
- Waste Chute Bags. Contact your laboratory supply dealer.

Optional accessories for on-site installation include:

- Additional Transfer Caddy. See page 43.
- Trace Odor Carbon Filters. See page 41.
- Utility Shelves, Bottle Holder and Tissue Holder. See page 42.
- Exhaust Dampers. See pages 45-46.

■ Exclusive feature

* U.S. Patent No. 6,461,233

** Patent pending

† Ring selected should be a minimum of 2" smaller than source container's inner bag diameter.

Nominal Width/Duct	Total Exhaust CFM and Initial Static Pressure (w.g.) ^{††}					
	100 fpm	S.P.	80 fpm	S.P.	60 fpm	S.P.
5 Feet/10" dia.	480	0.72"-0.85"	385	0.55"-0.67"	290	0.38"-0.46"
6 Feet/10" dia.	580	0.87"-1.03"	465	0.67"-0.81"	350	0.46"-0.56"

†† Static pressure loss through HEPA filter gradually increases as filter loads.



XPert® Bulk Powder Filtered Stations

ORDERING INFORMATION & DIMENSIONAL DATA

XPert Bulk Powder Filtered Stations

Nominal Width	Catalog Number	Overall Dimensions	Interior Dimensions	Electrical Requirements	Access Opening Position	Combined Shipping Weight lbs./kg*
5'	3962500	60.0" w x 37.0" d x 86.8" h	57.6" w x 30.0" d x 32.0" h	115 volts, 60 Hz	Left Side	945/429
5'	3962501	60.0" w x 37.0" d x 86.8" h	57.6" w x 30.0" d x 32.0" h	115 volts, 60 Hz	Center	945/429
5'	3962502	60.0" w x 37.0" d x 86.8" h	57.6" w x 30.0" d x 32.0" h	115 volts, 60 Hz	Right Side	945/429
5'	3962520**	60.0" w x 37.0" d x 86.8" h	57.6" w x 30.0" d x 32.0" h	230 volts, 50 Hz	Left Side	945/429
5'	3962521**	60.0" w x 37.0" d x 86.8" h	57.6" w x 30.0" d x 32.0" h	230 volts, 50 Hz	Right Side	945/429
5'	3962522**	60.0" w x 37.0" d x 86.8" h	57.6" w x 30.0" d x 32.0" h	230 volts, 50 Hz	Center	945/429
6'	3962600	72.0" w x 37.0" d x 86.8" h	69.6" w x 30.0" d x 32.0" h	115 volts, 60 Hz	Left Side	1075/488
6'	3962601	72.0" w x 37.0" d x 86.8" h	69.6" w x 30.0" d x 32.0" h	115 volts, 60 Hz	Center	1075/488
6'	3962602	72.0" w x 37.0" d x 86.8" h	69.6" w x 30.0" d x 32.0" h	115 volts, 60 Hz	Right Side	1075/488
6'	3962620**	72.0" w x 37.0" d x 86.8" h	69.6" w x 30.0" d x 32.0" h	230 volts, 50 Hz	Left Side	1075/488
6'	3962621**	72.0" w x 37.0" d x 86.8" h	69.6" w x 30.0" d x 32.0" h	230 volts, 50 Hz	Center	1075/488
6'	3962622**	72.0" w x 37.0" d x 86.8" h	69.6" w x 30.0" d x 32.0" h	230 volts, 50 Hz	Right Side	1075/488

*Shipped in two sections.

**International electrical configuration. No electrical plug included.

† Width does not include waste chute. Waste chute adds 1.3" to overall width.

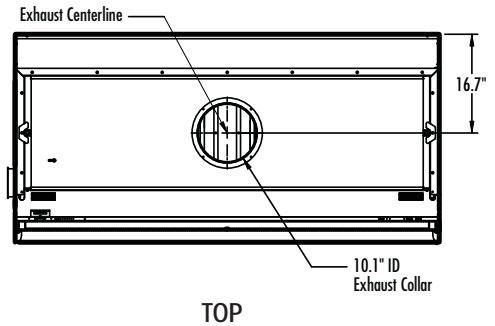
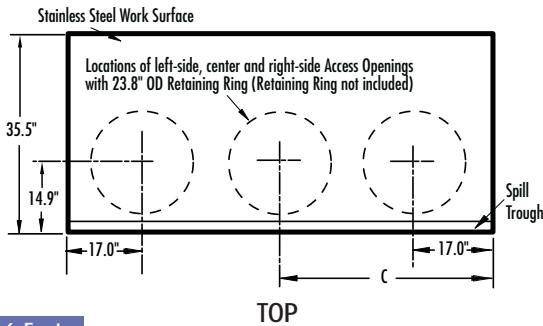

	5-Foot	6-Foot
A	60.0"	72.0"
B	57.6"	69.6"
C	30.0"	36.0"

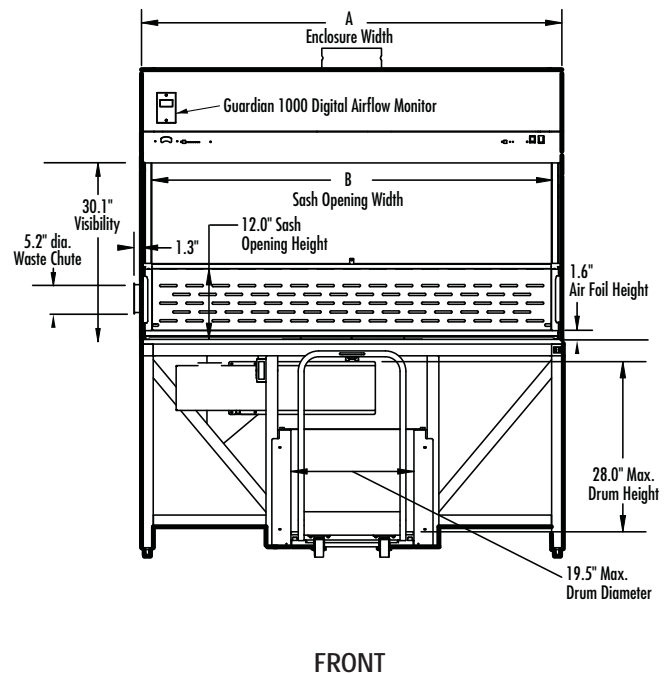
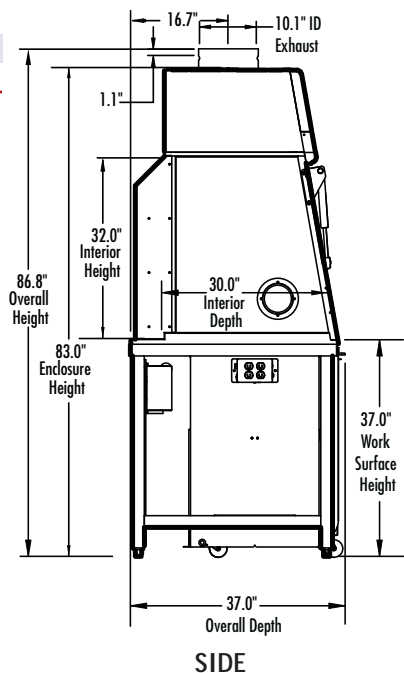



XPert® Bulk Powder Enclosures

SPECIFICATIONS



XPert Bulk Powder Enclosure 3963801 with Retaining Ring 3981300, Safety Sleeve 3981100 and Retaining Band 3981200.



Requires
Ductwork and
Blower

- Shipped in two sections.
- Three 2" x 10" rectangular exhaust openings on the top. Cover(s) provided for unused openings.
- Particulate containment independently verified by SafeBridge Consultants, Inc.
- Validation package available at www.labconco.com with powder containment and modified ASHRAE 110-1995 Test Reports; Installation Qualification/Operation Qualification (IQ/OQ) Protocol; and Maintenance Log.

All models conform to the following regulations and standards:

- SEFA 1-2002
- Modified ASHRAE 110-1995
- ANSI Z9.5-1993
- UL 3101-1/61010-1
- CAN/CSA C22.2 No. 1010.1
- CE Conformity Marking (230 volt models)

All models require:

- Remote Blower (sold separately). See page 44.
- Ductwork. See page 45 and inside back cover.
- Retaining Ring***. See page 43.
- Safety Sleeves**. See page 43.
- Retaining Bands**. See page 43.
- Access Opening Cover. See page 43.
- Waste Chute Bags. Contact your laboratory supply dealer.

Optional accessories for on-site installation include:

- Fluorescent Lights. See page 42.
- Additional Transfer Caddy. See page 43.
- Utility Shelves, Bottle Holder and Tissue Holder. See page 42.
- Duct Transition Adapters. See page 43.



* U.S. Patent No. 6,461,233 ** Patent pending
 † Ring selected should be a minimum of 2" smaller than source container's inner bag diameter.

All models feature:

- Ergonomic air foil with aerodynamic Clean-Sweep* airflow openings.
- Upper dilution air supply.
- Upper containment sash foil.
- Zone-perforated, pivoting rear baffle.*
- Side-entry air foils.
 - Guardian 1000 Digital Airflow Monitor that continuously monitors airflow and provides a digital readout of actual face velocity. An audible/visual alarm alerts the operator when airflow is outside set point range. RS232 communications port allows connection to user-supplied computer and may be configured for external input connections such as night setback or external alarm and up to three output relays. Includes epoxy-coated steel housing for mounting.
- Stainless steel work surface with front spill trough and right-side, center or left-side access opening for source container (drum).
- 2" square tubular steel base stand with leveling feet.
- Transfer caddy of glacier white, epoxy-coated 1" square tubular steel frame with 3" diameter caster that holds container up to 28" h x 19.5" dia. With caddy latch and positioning plate.**

- Push-button operated electric hydraulic lift mechanism for raising the container to the optimal ergonomic height (14" maximum travel distance).**
- Electronic beam to sense the location of the container and trigger the lift mechanism to automatically stop at the optimal access height.**
- Left side-mounted waste chute. Bags not included. Minimum bag size required: 10" x 16".
- Fourplex electrical receptacle located underneath the work surface.
- 1/4" thick tempered safety glass front sash, sides and top.
- Glacier white and gray, dry powder epoxy-coated aluminum frame and steel rear plenum and baffle. No unreliable plastic-to-plastic bonding is used.
- Ergonomic angled and hinged, pivoting sash with wiping seal, external gas-assist lift, 12.0" sash opening height, 25.75" locking height and 28.25" maximum loading height.
- Two utility ports for pass-through of electrical cords.

Nominal Width/Duct	Total Exhaust CFM and Initial Static Pressure (w.g.)					
	100 fpm	S.P.	80 fpm	S.P.	60 fpm	S.P.
5 Feet/10" dia.	480	0.54"	385	0.35"***	290	0.20"
6 Feet/10" dia.	580	0.75"	465	0.48"***	350	0.27"
8 Feet/10" dia.	775	0.42"	620	0.27"††	465	0.15"

*** Static pressure when one center exhaust opening is used.

†† Static pressure when two outer exhaust openings are used. Requires a "T" Connector 3981600, not included. See page 45.



XPert® Bulk Powder Enclosures

ORDERING INFORMATION & DIMENSIONAL DATA

XPert Bulk Powder Enclosures

Nominal Width	Catalog Number	Overall Dimensions	Interior Dimensions	Electrical Requirements	Access Opening Position	Combined Shipping Weight lbs./kg*
5'	3963500	60.0 ^{††} w x 37.0" d x 75.5 ^{†††} h	58.8" w x 30.0" d x 31.5" h	115 volts, 60 Hz	Left Side	870/395
5'	3963501	60.0 ^{††} w x 37.0" d x 75.5 ^{†††} h	58.8" w x 30.0" d x 31.5" h	115 volts, 60 Hz	Center	870/395
5'	3963502	60.0 ^{††} w x 37.0" d x 75.5 ^{†††} h	58.8" w x 30.0" d x 31.5" h	115 volts, 60 Hz	Right Side	870/395
5'	3963520**	60.0 ^{††} w x 37.0" d x 75.5 ^{†††} h	58.8" w x 30.0" d x 31.5" h	230 volts, 50 Hz	Left Side	870/395
5'	3963521**	60.0 ^{††} w x 37.0" d x 75.5 ^{†††} h	58.8" w x 30.0" d x 31.5" h	230 volts, 50 Hz	Center	870/395
5'	3963522**	60.0 ^{††} w x 37.0" d x 75.5 ^{†††} h	58.8" w x 30.0" d x 31.5" h	230 volts, 50 Hz	Right Side	870/395
6'	3963600	72.0 ^{††} w x 37.0" d x 75.5 ^{†††} h	70.8" w x 30.0" d x 31.5" h	115 volts, 60 Hz	Left Side	1000/454
6'	3963601	72.0 ^{††} w x 37.0" d x 75.5 ^{†††} h	70.8" w x 30.0" d x 31.5" h	115 volts, 60 Hz	Center	1000/454
6'	3963602	72.0 ^{††} w x 37.0" d x 75.5 ^{†††} h	70.8" w x 30.0" d x 31.5" h	115 volts, 60 Hz	Right Side	1000/454
6'	3963620**	72.0 ^{††} w x 37.0" d x 75.5 ^{†††} h	70.8" w x 30.0" d x 31.5" h	230 volts, 50 Hz	Left Side	1000/454
6'	3963621**	72.0 ^{††} w x 37.0" d x 75.5 ^{†††} h	70.8" w x 30.0" d x 31.5" h	230 volts, 50 Hz	Center	1000/454
6'	3963622**	72.0 ^{††} w x 37.0" d x 75.5 ^{†††} h	70.8" w x 30.0" d x 31.5" h	230 volts, 50 Hz	Right Side	1000/454
8'	3963800	96.0 ^{††} w x 37.0" d x 75.5 ^{†††} h	94.8" w x 30.0" d x 31.5" h	115 volts, 60 Hz	Left Side	1300/590
8'	3963801	96.0 ^{††} w x 37.0" d x 75.5 ^{†††} h	94.8" w x 30.0" d x 31.5" h	115 volts, 60 Hz	Center	1300/590
8'	3963802	96.0 ^{††} w x 37.0" d x 75.5 ^{†††} h	94.8" w x 30.0" d x 31.5" h	115 volts, 60 Hz	Right Side	1300/590
8'	3963820**	96.0 ^{††} w x 37.0" d x 75.5 ^{†††} h	94.8" w x 30.0" d x 31.5" h	230 volts, 50 Hz	Left Side	1300/590
8'	3963821**	96.0 ^{††} w x 37.0" d x 75.5 ^{†††} h	94.8" w x 30.0" d x 31.5" h	230 volts, 50 Hz	Center	1300/590
8'	3963822**	96.0 ^{††} w x 37.0" d x 75.5 ^{†††} h	94.8" w x 30.0" d x 31.5" h	230 volts, 50 Hz	Right Side	1300/590

*Shipped in two sections.

** International electrical configuration. No electrical plug included.

† Width does not include waste chute. Waste chute adds 1.3" to overall width.

†† Height includes Exhaust Transition Adapter (sold separately).

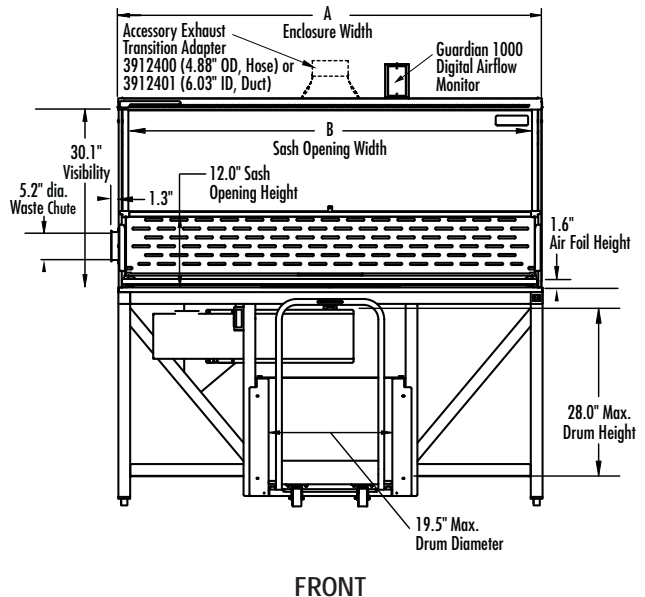
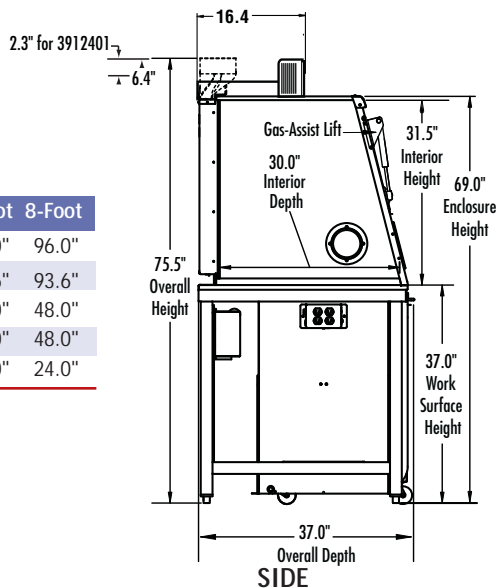
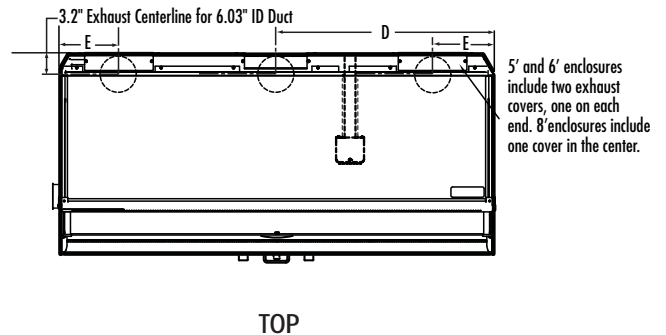
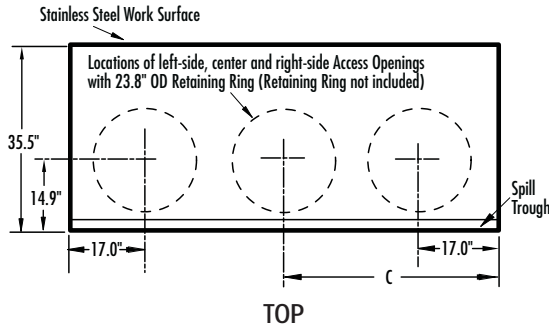

	5-Foot	6-Foot	8-Foot
A	60.0"	72.0"	96.0"
B	57.6"	69.6"	93.6"
C	30.0"	36.0"	48.0"
D	30.0"	36.0"	48.0"
E	10.0"	10.0"	24.0"



FilterMate™ Portable Exhausters

SPECIFICATIONS



FilterMate Portable Exhauster #3970000. Includes HEPA filter.



FilterMate Portable Exhauster #3970001. Requires carbon filter (not included).



FilterMate Portable Exhauster #3970002. Includes HEPA filter and thimble connection. Requires ducting to outside.



FilterMate Portable Exhauster #3970003. Includes HEPA filter. Requires carbon filter (not included).

An accessory for the XPert® Balance Enclosure, the FilterMate uses a HEPA filter, carbon filter or a combination of both filters to remove hazardous powders, particulates or vapors from the exhaust air stream, returning filtered air to the environment.

All models feature:

- Compact, corrosion-resistant housing of glacier white and light gray, dry powder epoxy-coated steel with rubber feet.
- Variable-speed, non-sparking motorized impeller.
- ❑ Quiet operation. Oversized HEPA filter, efficient impeller and perforated exhaust cover work together to provide lower system exhaust velocity and noise pressure levels.

Exhaust CFM	Noise Pressure dB(A)
100	45-47
150	51-54
200	56-61
250	63-65

- ❑ Inherently safe design. A negative pressure plenum surrounds the positive pressure impeller so that if a leak occurs, the unfiltered air is captured and refiltered.
- ❑ Capable of up to 200 CFM for combination HEPA/carbon filtration (60-100 fpm depending on enclosure model).
- Front-mounted rocker switch to control power to the blower.
- ❑ Rear-mounted, auxiliary electrical outlet that may be connected to an airflow monitor or other user-supplied accessories.
- ❑ Only one FilterMate is required for 2', 3' and 4' wide enclosures. Contact Labconco for technical assistance regarding using multiple FilterMates for 5', 6' and 8' wide enclosures.

- ❑ Included: 8 feet of 5" ID flexible gray polypropylene hose, two clamps and a 4.88" OD Upper Transition Adapter for connection to the top of the XPert Balance Enclosure. Models 3970004 and 3970024 include a 4.88" OD Lower Transition Adapter instead of the Upper Transition Adapter.

- IEC 3-wire electrical cord with plug.

All models conform to the following regulations and standards:

- UL 3101-1/61010-1
- CAN/CSA C22.2 No. 1010.1
- CE Conformity Marking (230 volt models)

Models 3970000, 3970020, 3970002, 3970022, 3970003 and 3970023 feature:

- HEPA filter, 99.99% efficient on particulates 0.3 micron in size.
- ❑ True bag-in/bag-out filter disposal system for safely removing and replacing the filter without detaching the hose. The HEPA filter may be easily accessed by removing the exhaust cover for field leak testing by a certified technician.

Models 3970002 and 3970022 feature:

- 6.06" ID thimble connection from the FilterMate to an existing house exhaust system for added safety.

Models 3970001, 3970021, 3970003 and 3970023 require one each and Models 3970004 and 3970024 require two each (not included):

- Carbon Filter. Organic Vapor, Formaldehyde or Ammonia Filters are offered. See page 38.

Optional Accessories

- Replacement HEPA Filter. See page 38.
- Replacement Bag for Bag-In/Bag-Out HEPA Filter. See page 38.

❑ Exclusive feature





FilterMate™ Portable Exhausters

ORDERING INFORMATION & DIMENSIONAL DATA

FilterMate Portable Exhausters

Catalog Number	Filter Usage	Overall Dimensions	Electrical Requirements	Airflow Potential	Exhaust Connection	Shipping Weight lbs./kg
3970000	HEPA included	14.0" w x 23.0" d x 22.7" h	115 volts, 60 Hz	250 CFM (60-100 fpm)	None. Room exhaust.	50/22.7
3970020*	HEPA included	14.0" w x 23.0" d x 22.7" h	230 volts, 50 Hz	250 CFM (60-100 fpm)	None. Room exhaust.	50/22.7
3970001	Carbon required†	14.0" w x 23.0" d x 22.7" h	115 volts, 60 Hz	250 CFM (60-100 fpm)	None. Room exhaust.	48/21.8
3970021*	Carbon required†	14.0" w x 23.0" d x 22.7" h	230 volts, 50 Hz	250 CFM (60-100 fpm)	None. Room exhaust.	48/21.8
3970002	HEPA included	18.6" w x 23.0" d x 24.7" h	115 volts, 60 Hz	250 CFM (60-100 fpm)	6.06" ID Thimble to outside	54/24.5
3970022*	HEPA included	18.6" w x 23.0" d x 24.7" h	230 volts, 50 Hz	250 CFM (60-100 fpm)	6.06" ID Thimble to outside	54/24.5
3970003	HEPA included†† Carbon required†	14.9" w x 23.0" d x 22.7" h	115 volts, 60 Hz	200 CFM (60-100 fpm)**	None. Room Exhaust.	52/23.6
3970023*	HEPA included†† Carbon required†	14.9" w x 23.0" d x 22.7" h	230 volts, 50 Hz	200 CFM (60-100 fpm)**	None. Room Exhaust.	52/23.6
3970004	Two Carbon required†	14.9" w x 23.0" d x 22.7" h	115 volts, 60 Hz	200 CFM (60-100 fpm)**	None. Room Exhaust.	52/23.6
3970024*	Two Carbon required†	14.9" w x 23.0" d x 22.7" h	230 volts, 50 Hz	200 CFM (60-100 fpm)**	None. Room Exhaust.	52/23.6

* International electrical configuration † Carbon Filter(s) not included. †† HEPA filter may be removed and substituted with a second carbon filter. ** 60-80 fpm on 4' enclosure.

**Models 3970000, 3970001,
3970020 & 3970021**

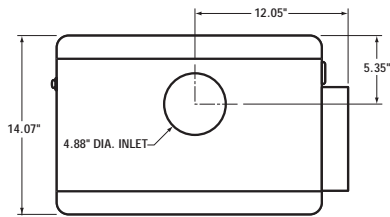

TOP

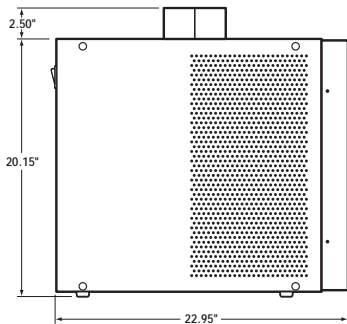

SIDE

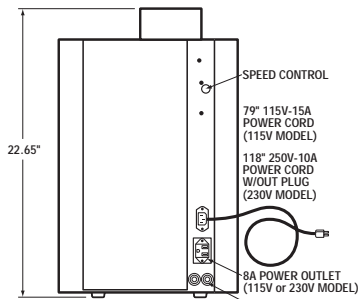

REAR

Models 3970002 & 3970022

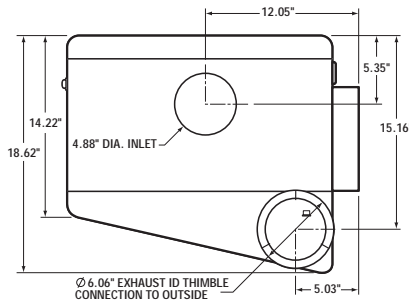

TOP

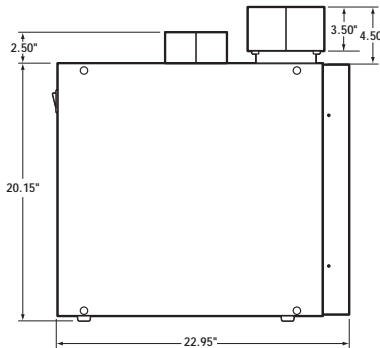

SIDE

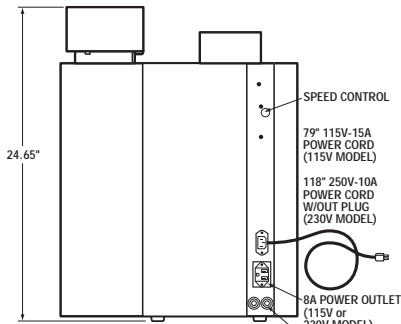

REAR

**Models 3970003 & 3970023,
3970004 & 3970024**

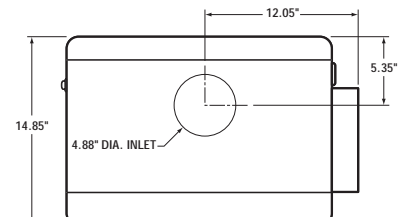

TOP

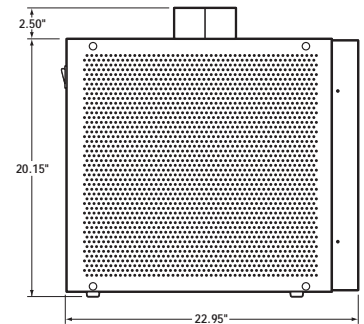

SIDE

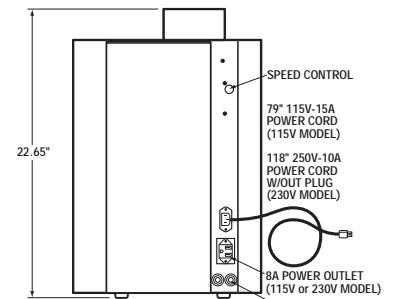

REAR



FilterMate™ Carbon and HEPA Filters



Organic Carbon Filter
3923400.



Replacement HEPA Filter
3707900.

Below is an Application Matrix that provides examples of appropriate uses for Filters expended in the FilterMate Portable Exhauster. Whether or not the FilterMate would be appropriate for your application requires consideration of factors such as the time-weighted exposure limits of your materials. Using Labconco's exclusive Chemical Assessment Program, our technical specialists can help you determine if the XPert Balance Enclosure with FilterMate Portable Exhauster is the right ventilation product for your application and, if so, estimate filter life. To begin the process, please complete the Chemical Usage Assessment Form available on our website at: www.labconco.com/chemical_usage.html or call us at 800-821-5525 or 816-333-8811.

Ordering Information

Catalog Number	Description	Shipping Weight lbs./kg
3923400	Organic Carbon Filter, Type AC. Contains 12 pounds of granular activated carbon media suitable for organic solvents including acetone, ethyl acetate, toluene and xylene.	13/6
3923401	Formaldehyde Carbon Filter, Type CI. Contains 14 pounds of impregnated carbon media suitable for vapors from formaldehyde.	17/8
3923402	Ammonia Carbon Filter, Type CX. Contains 16 pounds of impregnated carbon media suitable for ammonia and low molecular weight amines.	21/10
6924900	Syringe Kit for carbon saturation detection. Contaminant detector tubes sold separately.*	1/0.5
6926000	Formaldehyde Detector Tubes, package of 3.	1/0.5
6925700	Ammonia Detector Tubes, package of 3.	1/0.5
3707900	Replacement HEPA Filter, 99.99% efficient on particles 0.3 micron in size. Not suitable for use with biohazardous materials or volatile organic material.	10/5
3776002	Replacement Bag for Bag-In/Bag-Out HEPA Filter to contain particulate matter during filter changing.	1/0.5

Application Matrix

For FilterMate Models:	3970001, 3970021, 3970004 & 3970024			3970003 & 3970023	3970000, 3970020, 3970002, & 3970022
Type/Configuration:	Organic	Ammonia	Formaldehyde	HEPA/Carbon**†	HEPA
Asbestos handling					•
Combination dry and liquid chemicals				•	
Drug compounding/research				•	•
Endoscopy instrument cleaning			•		
Histology/cytology tissue staining, coverslipping	•				
Histology/pathology	•		•	•	
Hormone research				•	•
Non-biohazardous microbiological samples with trace chemicals				•	
Particulates in conjunction with chemical agents				•	
Pathology/tissue grossing			•	•	
Photo-engraving		•			
Plastics production		•			
Pollen handling					•
Soldering				•	•
Solvent cleaning	•				
Solvent welding/gluing	•				
Weighing chemical powders				•	•

* Contaminant detector tubes indicate the presence of a specific set of contaminants with a color change. Labconco offers Formaldehyde and Ammonia Detector Tubes. Detector tubes for organic vapors may be ordered from your laboratory supply distributor.

** Carbon filter type varies based on application.

† HEPA filter is placed above the carbon filter on the FilterMate so that particulate contaminants are removed first.



Protector® Standard Storage Cabinets



Protector Standard Storage Cabinet 9900000, 48" wide, with dual doors.





Protector Standard Storage Cabinets support XPert Enclosures and may be used for storage of supplies and small laboratory instruments.

Features:

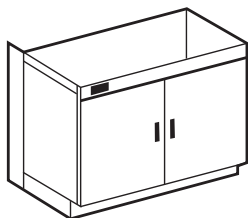
- Support XPert Filtered Balance Systems, Filtered Balance Stations and Balance Enclosures.
- Durable epoxy-coated steel construction.
- Attractive glacier white exterior complements laboratory casework and XPert Enclosures.
- Manual-closing, non-locking door(s).
- Include four leveling feet and one 8" filler panel to increase cabinet depth from 22" to 30".
- **Work surface is required** (sold separately). See page 41.

Ordering Information



Catalog #	Cabinet Dimensions (w x d x h)	Depth with standard filler panel	Door(s)	Shipping Wt. lbs./kg
9900000	48.0" x 22.0" x 35.5" to 36.75"	30.0"	Dual	260/118
9900100	36.0" x 22.0" x 35.5" to 36.75"	30.0"	Dual	180/82
9900300	24.0" x 22.0" x 35.5" to 36.75"	30.0"	Single Right Hinge	130/59
9900500	12.0" x 22.0" x 35.5" to 36.75"	30.0"	Single Right Hinge	65/29
9900600	24.0" x 22.0" x 35.5" to 36.75"	30.0"	Single Left Hinge	130/59
9900800	12.0" x 22.0" x 35.5" to 36.75"	30.0"	Single Left Hinge	65/29
9904000	 24.0" x 22.0" x 31.5" to 32.75"	30.0"	Single Right Hinge	120/54
9904200	 12.0" x 22.0" x 31.5" to 32.75"	30.0"	Single Right Hinge	60/27
9904300	 24.0" x 22.0" x 31.5" to 32.75"	30.0"	Single Left Hinge	120/54
9904500	 12.0" x 22.0" x 31.5" to 32.75"	30.0"	Single Left Hinge	60/27

Dimensional Data

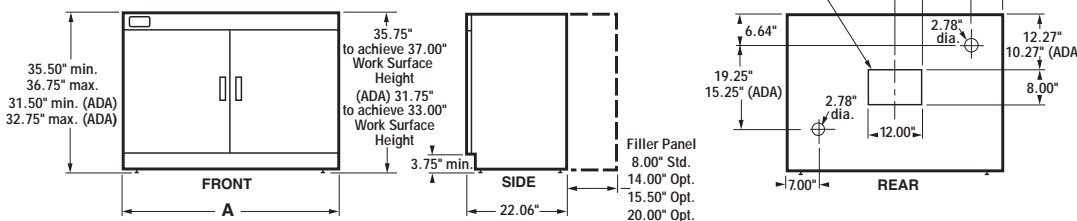

Model	A	B
48.0"	48.0"	24.0"
36.0"	36.0"	18.0"
24.0"	24.0"	12.0"
12.0"	12.0"	—
24.0" ADA	24.0"	12.0"
12.0" ADA	12.0"	—

 Cabinet height meets requirements of the Americans with Disabilities Act.

Contact Labconco at 800-821-5525 or 816-333-8811 for ordering information on other base cabinets.



Telescoping Base Stands



Telescoping Base Stand with Fixed Feet 3746702.

Inset: Telescoping Base Stand with Casters 3746710.



Telescoping Base Stands provide support for XPert Balance Enclosures.*

Features:

- Support XPert Filtered Balance Systems, Filtered Balance Stations and Balance Enclosures.
- Durable 1.75" tubular, epoxy-coated steel frame. Models 3' wide and larger have rear crossbar supports.
- Telescoping legs are adjustable to seven height positions in 1" increments from 27.5" to 33.5".**
- Available with four fixed leveling feet or 5" diameter, toe-locking, non-marking polyurethane casters with bearings for quiet operation.
- **Work surface is required** (sold separately). See page 41.

Contact Labconco at **800-821-5525** or **816-333-8811** for ordering information on other base stands.



Ordering Information

Catalog #	Overall Dimensions (w x d)	Description	Shipping Wt. lbs./kg
3746700	24.0" x 29.0"	with fixed feet	100/45
3746710	24.0" x 29.0"	with casters	100/45
3746701	36.0" x 29.0"	with fixed feet	110/50
3746711	36.0" x 29.0"	with casters	110/50
3746702	48.0" x 29.0"	with fixed feet	115/52
3746712	48.0" x 29.0"	with casters	115/52
3746703	60.0" x 29.0"	with fixed feet	120/54
3746713	60.0" x 29.0"	with casters	120/54
3746704	72.0" x 29.0"	with fixed feet	125/57
3746714	72.0" x 29.0"	with casters	125/57

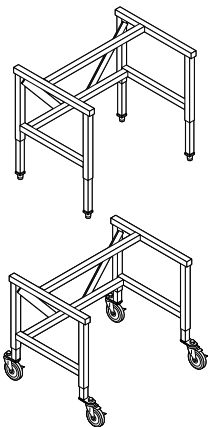

Accessory Shelves

Glacier white, epoxy-coated, 16 gauge steel. Designed to hook on the lower rear horizontal cross member of the Telescoping Base Stand. Provides storage space for wipes, cleaning agents, gloves and other miscellaneous laboratory supplies. One each.

Nominal Width	Catalog #	Shelf Width x Depth	Shipping Weight
2-Ft	3811100	20.4" x 9.9"	9 lbs. (4 kg)
3-Ft	3811101	32.4" x 9.9"	12 lbs. (5 kg)
4-Ft	3811102	44.4" x 9.9"	15 lbs. (7 kg)
5-Ft	3811103	56.4" x 9.9"	19 lbs. (9 kg)
6-Ft	3811104	68.4" x 9.9"	23 lbs. (10 kg)

Dimensional Data

Catalog #	A
3746700, 3746710	24.0"
3746701, 3746711	36.0"
3746702, 3746712	48.0"
3746703, 3746713	60.0"
3746704, 3746714	72.0"

With Fixed Feet

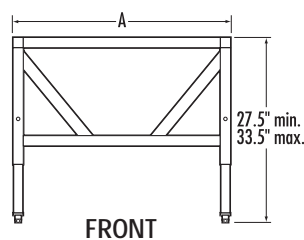

FRONT

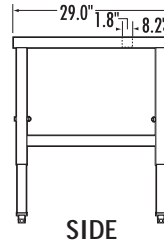

SIDE

With Casters

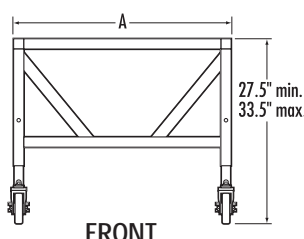

FRONT

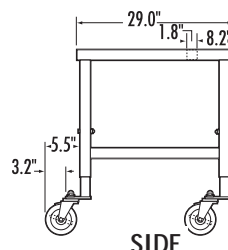

SIDE

* Telescoping Base Stands do not isolate vibration. When using sensitive balances in the enclosure, a marble slab may be necessary to reduce vibration from outside influences.

** Height selection and adjustment are required before the enclosure is installed atop the stand.



XPert® Balance Enclosures and Bulk Powder Enclosures

ACCESSORIES



Solid Epoxy Work Surfaces

Black chemical-resistant work surfaces are dished to contain spills and contoured to fit the dimensions of XPert Balance Enclosures, Systems and Stations. Contact Labconco for ordering information on gray work surfaces. Available in 2', 3' and 4' widths.

Catalog #	Nominal Width	For use with:	Dimensions	Shipping Wt. lbs./kg
3909900	2'	XPert Systems, Stations	24.0" w x 29.0" d x 1.0" thick	50/23
3909901	3'	XPert Systems, Stations	36.0" w x 29.0" d x 1.0" thick	75/34
3909902	4'	XPert Systems, Stations	48.0" w x 29.0" d x 1.0" thick	100/45
3908400	2'	XPert Enclosures	24.0" w x 26.7" d x 1.0" thick	48/22
3908401	3'	XPert Enclosures	36.0" w x 26.7" d x 1.0" thick	72/33
3908402	4'	XPert Enclosures	48.0" w x 26.7" d x 1.0" thick	96/44



Stainless Steel Work Surfaces

Type 304 stainless steel work surfaces have a 1" deep front spill trough and fit dimensions of XPert Balance Enclosures, Systems and Stations. Available in 5', 6' and 8' widths.

Catalog #	Nominal Width	For use with:	Dimensions	Shipping Wt. lbs./kg
3975502	5'	29.0" deep XPert Systems, Stations	60.0" w x 29.0" d x 0.8" thick	150/68
3975503	5'	35.5" deep XPert Systems, Stations	60.0" w x 35.5" d x 0.8" thick	180/82
3975602	6'	29.0" deep XPert Systems, Stations	72.0" w x 29.0" d x 0.8" thick	180/82
3975603	6'	35.5" deep XPert Systems, Stations	72.0" w x 35.5" d x 0.8" thick	220/100
3975500	5'	29.0" deep XPert Enclosures	60.0" w x 26.7" d x 0.8" thick	140/64
3975501	5'	35.5" deep XPert Enclosures	60.0" w x 35.5" d x 0.8" thick	180/100
3975600	6'	29.0" deep XPert Enclosures	72.0" w x 26.7" d x 0.8" thick	170/77
3975601	6'	35.5" deep XPert Enclosures	72.0" w x 35.5" d x 0.8" thick	220/100
3975800	8'	29.0" deep XPert Enclosures	96.0" w x 26.7" d x 0.8" thick	240/109
3975801	8'	35.5" deep XPert Enclosures	96.0" w x 35.5" d x 0.8" thick	290/132



Trace Odor Carbon Filters for XPert Filtered Systems

For easy installation atop the XPert Filtered Systems. Filters trap non-volatile nuisance odors and vapors from samples or minute quantities of chemicals. Whether or not a Trace Odor Carbon Filter is appropriate for your application requires consideration of factors such as the time-weighted exposure limits of organic solvents, formaldehyde, ammonia or amines. Using Labconco's exclusive chemical assessment program, our technical specialists can help you determine if the XPert Filtered System with Trace Odor Carbon Filter is right for your applications and, if so, estimate filter life.

To begin the process, please complete the Chemical Usage Assessment Form available on our website at: www.labconco.com/chemical_usage.html or call us at 800-821-5525 or 816-333-8811.

Catalog #	Description	For use with:	Shipping Wt. lbs./kg
3937200	Organic, 5.5 lbs. activated carbon	2-Ft XPert System	6/3
3937300	Organic, 9.2 lbs. activated carbon	3-Ft & 6-Ft XPert Systems (2 required for 6-Ft Systems)	10/5
3937400	Organic, 12.9 lbs. activated carbon	4-Ft XPert System	13/6
3981400	Organic, 7.3 lbs. activated carbon	5-Ft XPert System (2 required)	8/4
3937201	Formaldehyde, 7.0 lbs. impregnated carbon	2-Ft XPert System	7.5/3
3937301	Formaldehyde, 12.0 lbs. impregnated carbon	3-Ft & 6-Ft XPert Systems (2 required for 6-Ft Systems)	12.5/6
3937401	Formaldehyde, 16.8 lbs. impregnated carbon	4-Ft XPert System	17/8
3981401	Formaldehyde, 9.5 lbs. impregnated carbon	5-Ft XPert System (2 required)	10/5
3937202	Ammonia & Amines, 8.0 lbs. impregnated carbon	2-Ft XPert System	8.5/4
3937302	Ammonia & Amines, 13.5 lbs. impregnated carbon	3-Ft & 6-Ft XPert Systems (2 required for 6-Ft Systems)	14/4
3937402	Ammonia & Amines, 18.9 lbs. impregnated carbon	4-Ft XPert System	19/9
3981402	Ammonia & Amines, 10.7 lbs. impregnated carbon	5-Ft XPert System (2 required)	11/5



XPert® Balance Enclosures and Bulk Powder Enclosures

ACCESSORIES



XPert Filtered System and Station Replacement HEPA Filters and Accessories*

Catalog #	Description	For use with:	Shipping Weight
3707900	Replacement HEPA Filter, 99.99% efficient on particles 0.3 micron in size, 18.0" w x 18.0" d x 3.3" high	2-Ft XPert System, Station	8 lbs. (4 kg)
3707901	Replacement HEPA Filter, 99.99% efficient on particles 0.3 micron in size, 30.0" x 18.0" x 3.3" high	3-Ft XPert System, Station 6-Ft XPert System, Station (2 req.)	15 lbs. (7 kg)
3707902	Replacement HEPA Filter, 99.99% efficient on particles 0.3 micron in size, 42.0" w x 18.0" d x 3.3" high	4-Ft XPert System, Station	20 lbs. (9 kg)
3707903	Replacement HEPA Filter, 99.99% efficient on particles 0.3 micron in size 24.0" w x 18.0" d x 3.3" high	5-Ft XPert System, Station (2 required)	13 lbs. (6 kg)
3776003	Replacement Bag for Bag-in/Bag-out, HEPA Filter, 48" circumference x 54" long	2-Ft XPert System, Station	5 lbs. (2 kg)
3776004	Replacement Bag for Bag-in/Bag-out, HEPA Filter, 73" circumference x 96" long	3-Ft XPert System, Station 6-Ft XPert System, Station (2 req.)	7 lbs. (3 kg)
3776005	Replacement Bag for Bag-in/Bag-out, HEPA Filter, 96" circumference x 96" long	4-Ft XPert System, Station	9 lbs. (4 kg)
3776006	Replacement Bag for Bag-in/Bag-out, HEPA Filter, 60" circumference x 72" long	5-Ft XPert System, Station (2 required)	6 lbs. (3 kg)

* HEPA filter removal and replacement should only be performed by a certified technician.

Fluorescent Lights for XPert Enclosures

Rest atop XPert Enclosures for enhanced illumination of the interior. Include auxiliary electrical receptacle with switch for connection of accessories such as a printer or airflow monitor. More than one may be used on larger enclosures. 18.3" w x 10.1" d x 3.0" high.



Catalog #	Description	Shipping Wt. lbs./kg
3909200	115 volts, 60 Hz, 10 amps. Includes IEC, three-wire cord with plug.	15/7
3909201*	230 volts, 50 Hz, 10 amps. Includes IEC, three-wire cord. Plug is required (not included).	15/7



3925000 Utility Shelves

For use with any XPert Enclosure, Station or System. Three epoxy-coated steel shelves attach to the rear baffle perforations to hold a

printer, utensils and other miscellaneous weighing supplies. The utensil shelf has a scalloped front edge to support spatulas, brushes and other items. Shipping weight 5 lbs. (2 kg)



3927700 Bottle Holder

For use with any XPert Enclosure, Station or System. Epoxy-coated steel. Attaches to the rear baffle perforations to hold a squirt bottle or other round container. 3" diameter opening. Shipping weight 1 lb. (0.5 kg)



3927800 Tissue Holder

For use with XPert Enclosure, System or Station. Epoxy-coated steel. Attaches to the rear baffle perforations to hold tissue wipers in the upside down position.

An opening in the holder permits wipers to be dispensed from the bottom. Shipping weight 1 lb. (0.5 kg)



3744000 Ergonomic Chair with Armrests

Chair has 6-way articulating seat and back control for personalized adjustment. Pneumatic mechanism adjusts seat height from 18.25" to 25.75". Five-leg black reinforced composite base rests on 2" ball-bearing casters. Aluminum support ring. Removable arm rests. Black vinyl upholstery. Shipping weight 35 lbs. (16 kg)



3746000 Adjustable Footrest

Elevates feet and permits angle repositioning while in use. 18.5" w x 11.5" d x 8" high. Shipping weight 6 lbs. (3 kg)



XPert® Balance Enclosures and Bulk Powder Enclosures

ACCESSORIES

Safety Sleeves*

For use with XPert Bulk Powder Filtered Systems, Stations and Enclosures. Provide an extra barrier between the source container and work surface. Polyethylene. One size fits all source containers. Dimensions: 36.0" diameter x 18.0" long x .0015" thick.

Catalog #	Description	Shipping Wt. lbs./kg
3981100	Package of 100	3/1
3981101	Package of 500	15/7

3981200 Retaining Bands*

For use with XPert Bulk Powder Filtered Systems, Stations and Enclosures. Secure the Safety Sleeve and inner source container bag to the Retaining Ring. Bands fit all sizes of Retaining Rings. May be discarded after use or cleaned and reused. Package of 5. Shipping Weight 1 lb. (0.5 kg)



3961300 Transfer Caddy*

One is included with every XPert Bulk Powder Enclosure, Filtered System and Station. An additional caddy may expedite source container retrieval. Durable glacier white, epoxy-coated 1" square steel frame with 3" diameter casters. With caddy latch and positioning plate. Shipping weight 35 lbs. (16 kg)



Retaining Rings*

For use with XPert Bulk Powder Filtered Systems, Stations and Enclosures. Mount to the work surface to secure the inner source container bag and/or Safety Sleeve. Type 304 stainless steel.

Select a Retaining Ring that is slightly larger than the diameter of the source container to facilitate container lid removal and a minimum of 2" smaller than the source container's inner bag diameter. Include six fasteners. 23.8" OD.

Catalog #	Ring Diameter	Shipping Wt. lbs./kg
3981300	19.62" ID	4.5/2
3981301	17.50" ID	5.0/2
3981302	14.50" ID	5.5/3
3981303	11.50" ID	6.0/3

3981304 Access Opening Cover*



For use with XPert Bulk Powder Filtered Systems, Stations and Enclosures. Covers the opening and provides a flat surface. Type 304 stainless steel. Includes six fasteners.

23.8" OD. Shipping weight 10 lbs. (5 kg)

*Patent pending

Duct Transition Adapters for XPert Enclosures



Catalog #	Description	Shipping Wt. lbs./kg
3912400	Upper Exhaust Transition Adapter, epoxy-coated steel, 2" x 10" rectangular to 5" diameter round for connection to 5" ID hose (included with FilterMate Portable Exhauster)	5/2
3912401	Upper Exhaust Transition Adapter, epoxy-coated steel, 2" x 10" rectangular to 6" diameter round for connection to 6" OD duct	5/2
3912402	Lower Exhaust Transition Adapter, epoxy-coated steel, 2" x 10" rectangular to 5" diameter round for connection to 5" ID hose	5/2
3912403	Lower Exhaust Transition Adapter, epoxy-coated steel, 2" x 10" rectangular to 6" diameter round for connection to 6" OD duct	5/2

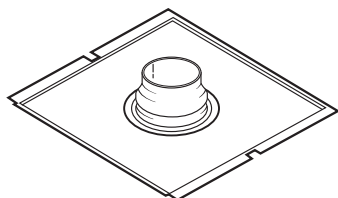

Canopy Connections for XPert Filtered Systems

Allow the XPert Filtered Systems to be thimble-ducted to the outside for additional protection. The canopy's air gap provides a means of balancing air by allowing room air to enter the ductwork and mix with the filtered air being exhausted from the XPert System. **House exhaust or remote blower is required (not included).**

Catalog #	Description	For use with:	Shipping Weight
3924400	Canopy Connection, 6.06" ID, 6.19" OD	2-Ft XPert System	15 lbs. (7 kg)
3924401	Canopy Connection, 6.06" ID, 6.19" OD	3-Ft XPert System	18 lbs. (8 kg)
3924402	Canopy Connection, 6.06" ID, 6.29" OD	4-Ft XPert System	21 lbs. (10 kg)
3924403	Canopy Connection, 10.06" ID, 10.29" OD	5-Ft XPert System	25 lbs. (11 kg)
3924404	Canopy Connection, 10.06" ID, 10.29" OD	6-Ft XPert System	30 lbs. (14 kg)
3924405	Canopy Connection, 5" ID*	2-Ft XPert System	15 lbs. (7 kg)
3924406	Canopy Connection, 5" ID*	3-Ft XPert System	18 lbs. (8 kg)
3924407	Canopy Connection, 5" ID*	4-Ft XPert System	21 lbs. (10 kg)

* For use with FilterMate Portable Exhausters



XPert® Balance Enclosures and Bulk Powder Enclosures

REMOTE BLOWERS FOR DUCTED SYSTEMS, STATIONS AND ENCLOSURES



Remote Blowers

Required when ducting the XPert Filtered Station or XPert Enclosure (unless connected to house exhaust or the FilterMate Portable Exhauster) and recommended when thimble ducting the XPert Filtered System. TEFC-type direct drive motor blower. Corrosion-resistant phenolic-coated steel housing and impeller. Blower inlet is sized to accept 6" nominal diameter PVC duct. Blower outlet is 4.3" x 7.4" OD. Dimensions: 14.6" w x 13.5" d x 13.3" high.

Catalog #	HP	Electrical Requirements	Shipping Wt. lbs./kg
4863500	1/4	115 volts, 60 Hz, 4.4 amps	35/16
7053501*	1/4	115 volts, 60 Hz, 4.4 amps	40/18
4863501**	1/4	115/230 volts, 50 Hz, 5.6/2.8 amps	35/16

CFM @ Static Pressure – Inches of H ₂ O						
S.P.	0.0"	0.125"	0.25"	0.50"	0.75"	0.87"
CFM	595	560	515	420	300	167



Remote Blowers

Required when ducting the XPert Filtered Station or XPert Enclosure (unless connected to house exhaust or the FilterMate Portable Exhausters) and recommended when ducting the XPert Filtered System. Belt drive motor blower. Corrosion-resistant phenolic-coated steel housing and impeller. Dry powder epoxy-coated base and weather cover. Blower inlet is sized to accept 10" nominal diameter PVC duct. Blower outlet is 5.5" x 10.0" OD. Dimensions: 16.1" w x 23.9" d x 22.6" high.

Catalog #	HP	Electrical Requirements	Shipping Wt. lbs./kg
7068200	1/4	115 volts, 60 Hz, 4.4 amps	92/42
7068300*	1/4	115 volts, 60 Hz, 4.5 amps	100/45
7068400	1/3	115 volts, 60 Hz, 6.1 amps	86/39
7068500*	1/3	115 volts, 60 Hz, 6.4 amps	94/43

CFM @ Static Pressure – Inches of H ₂ O								
	S.P.	0.25"	0.38"	0.50"	0.62"	0.75"	0.88"	1.00"
7068200, 7068300	CFM	540-720	410-760	350-710	390-620	430	—	—
7068400, 7068500	CFM	—	760-850	710-825	620-790	430-770	460-740	500-640

Blower Selection Guide

XPert Model	Recommended Blowers
2-Ft, 3-Ft, 4-Ft Filtered Balance Systems	4863500, 7053501, 4863501
4-Ft, 5-Ft, 6-Ft Balance & Bulk Powder Filtered Systems	7068200, 7068300, 7068400, 7068500
2-Ft, 3-Ft, 4-Ft Filtered Balance Stations	4863500, 7053501, 4863501
4-Ft, 5-Ft, 6-Ft Balance & Bulk Powder Filtered Stations	7068200, 7068300, 7068400, 7068500
2-Ft, 3-Ft, 4-Ft Balance Enclosures (standard and tall)	4863500, 7053501, 4863501
5-Ft, 6-Ft, 8-Ft Balance Enclosures (standard)	4863500, 7053501, 4863501
5-Ft, 6-Ft, 8-Ft Balance Enclosures (tall)	7068200, 7068300
5-Ft, 6-Ft, 8-Ft Bulk Powder Enclosures	7068200, 7068300

Blower selection should be based on desired face velocity, duct diameter and length of duct run.

An exhaust damper and/or larger blower may be required. Contact Labconco for blower sizing assistance.

*Explosion-proof **International electrical configuration



XPert® Balance Enclosures and Bulk Powder Enclosures

DUCTWORK

For XPert Enclosures, XPert Filtered Stations and Ducted XPert Filtered Systems

Catalog #	Description	Equivalent Resistance**	Shipping Weight
4708600	Thermoplastic Duct, 6.625" OD, 6.25" ID, 10' length	10'	25/11
4718900	Thermoplastic Duct, 8.625" OD, 8.25" ID, 10' length	10'	35/16
7027200	Thermoplastic Duct, 10.75" OD, 10.375" ID, 10' length	10'	50/23
4708900	Female PVC Duct Coupling, 6" nominal diameter, connects two sections of Thermoplastic Duct	0'	4/2
7027800	Male PVC Duct Coupling, 10" nominal diameter, 6" length, facilitates connection between Blowers, Elbows and Thermoplastic Duct Reducers	0'	5/2
4708700	90° PVC Elbow, 6" nominal diameter, has belled end connections to directly receive Thermoplastic Duct or Male Duct Coupling	12'	8/4
4719000	90° PVC Elbow, 8" nominal diameter, has belled end connections to directly receive Thermoplastic Duct or Male Duct Coupling	15'	10/5
7027300	90° PVC Elbow, 10" nominal diameter, has belled end connections to directly receive Thermoplastic Duct or Male Duct Coupling	20'	12/5
4861800	Flexible Duct Connection, 7" diameter for use with 6" diameter duct. Includes two hose clamps.	1'	5/2
7034200	Flexible Duct Connection, 11" diameter for use with 10" diameter duct. Includes two hose clamps.	1'	5/2
3924000	Manual Duct Damper, powder-coated steel, 6" nominal diameter	1'	10/5
3776800	Manual Duct Damper, powder-coated steel, 10" nominal diameter	2'	15/7
4741300	Manual Duct Damper, PVC, 8" nominal diameter	2'	12/5
3981600	6" x 6" x 8" Tee Connector, epoxy-coated steel, 5.94" OD x 5.94" OD x 7.94" OD, to directly receive 6" and 8" nominal diameter duct	5'	25/11
5606000	Thermoplastic Duct Reducer, to connect 8" nominal diameter duct to 10" nominal diameter duct	0'	5/2
4861700	Blower Transition Adapter, epoxy-coated steel, 4.25" x 7.75" rectangle to 6" diameter round	1'	3/1
4722400	Blower Transition Adapter, epoxy-coated steel, 5.5" x 10.0" rectangle to 8" diameter round	1'	3/1
4722401	Blower Transition Adapter, epoxy-coated steel, 5.5" x 10.0" rectangle to 10" diameter round	1'	4/2
4722200	Zero Pressure PVC Weathercap, 6" nominal diameter, fits atop thermoplastic duct, permits vertical discharge of effluent air for dispersion away from the building.	5'	20/9
4722300	Zero Pressure PVC Weathercap, 8" nominal diameter, fits atop thermoplastic duct, permits vertical discharge of effluent air for dispersion away from the building.	5'	30/14
7095100	Zero Pressure PVC Weathercap, 10" nominal diameter, fits atop thermoplastic duct, permits vertical discharge of effluent air for dispersion away from the building.	5'	25/11
3927400	Adapter, 5" nominal dia. x 6" nominal dia., powder-coated steel, for connecting a 2', 3' or 4' XPert Balance System with Canopy Connection or a 2', 3' or 4' XPert Balance Station to a FilterMate Portable Exhauster with Flexible Hose. Requires Flexible Hose 3927600 (not included).	0'	3/1
3927500	Flexible Hose, 5" ID, clear urethane, smooth bore with white helix, static dissipative, suitable for pharmaceutical and clean room applications. 8' length. Includes two clamps. For use with FilterMate Portable Exhauster.	8'	3/1
3927600	Flexible Hose, 6" ID, black thermoplastic rubber hose with 6.09" ID cuffs, suitable for pharmaceutical and clean room applications. 8' length. Includes two hose clamps. For connecting XPert Enclosure or XPert Filtered Station to house exhaust.	8'	3/1
4868600	Replacement Flexible Hose, 5" ID, gray polypropylene, suitable for general purpose and pharmaceutical applications. 8' length. Included with FilterMate Portable Exhauster.		
1921000	Replacement T-Bolt Hose Clamp, 5" diameter. Two are included with FilterMate Portable Exhauster.	—	1/0.5
1921500	Replacement T-Bolt Hose Clamp, 6" diameter. Two are included with Flexible Hose 3927600.	—	1/0.5

**Equivalent resistance is measured in feet of straight duct.



XPert® Balance Enclosures and Bulk Powder Enclosures

DUCTWORK COMPONENTS

XPert Enclosures Outside Ducting Options

FROM BOTTOM

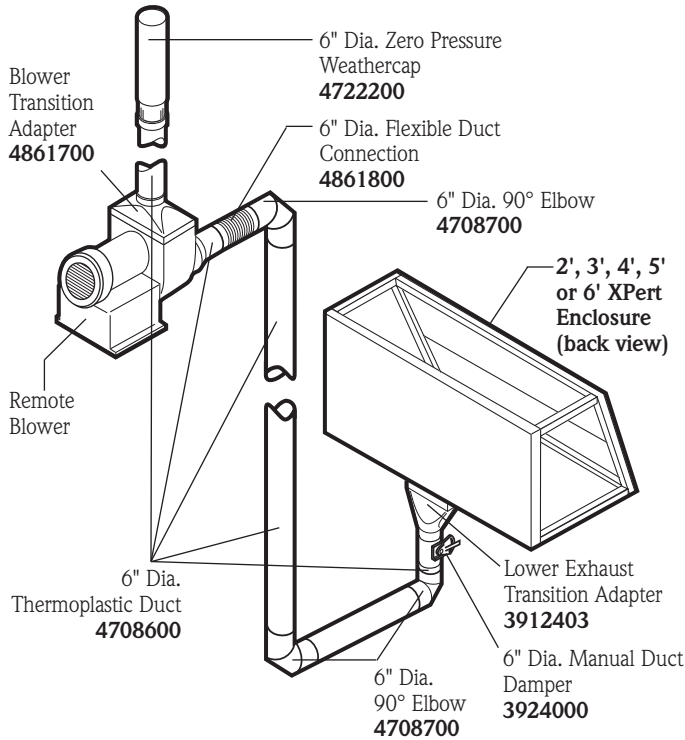

FROM TOP

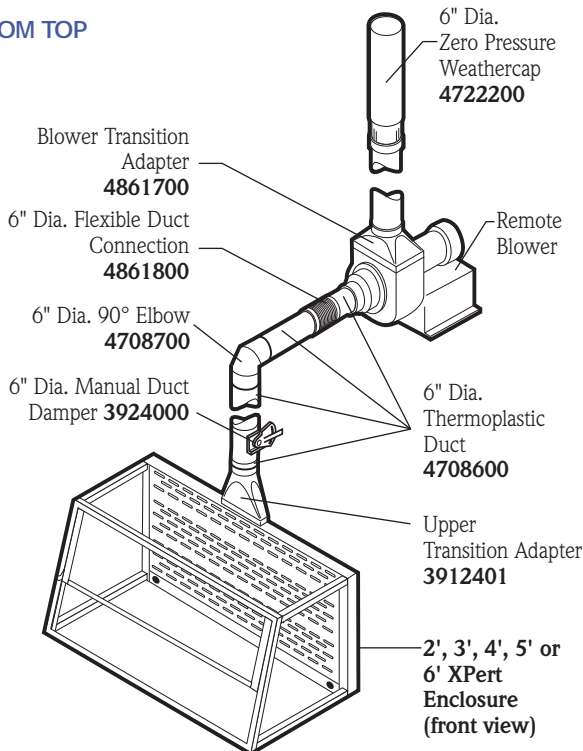

Contact Labconco for ducting options for XPert Enclosures connected to Remote Blower 7068200, 7068300, 7068400 or 7068500. See inside back cover for Typical Exhaust System for 8' XPert Enclosures.

XPert Filtered Station Typical Exhaust System

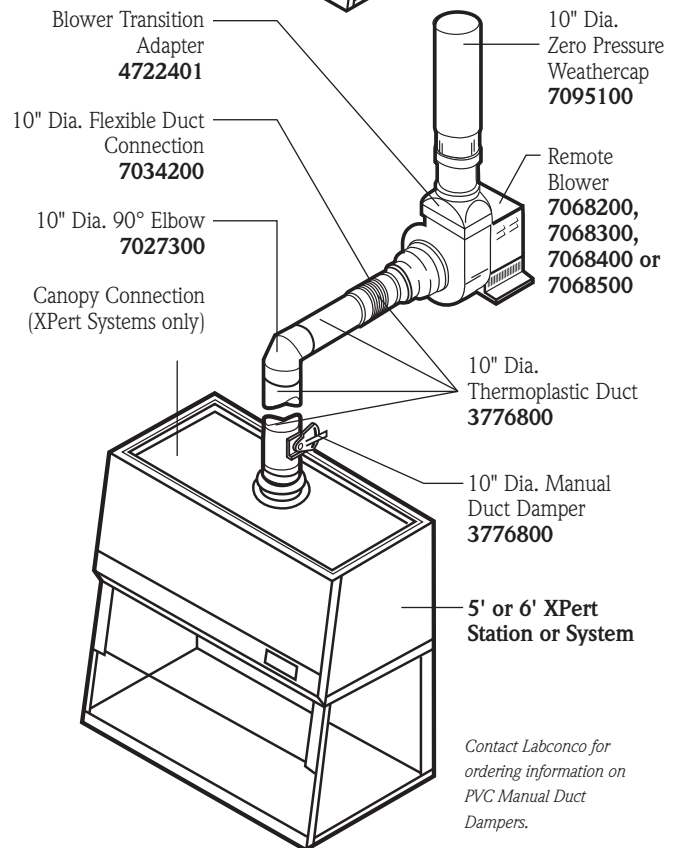
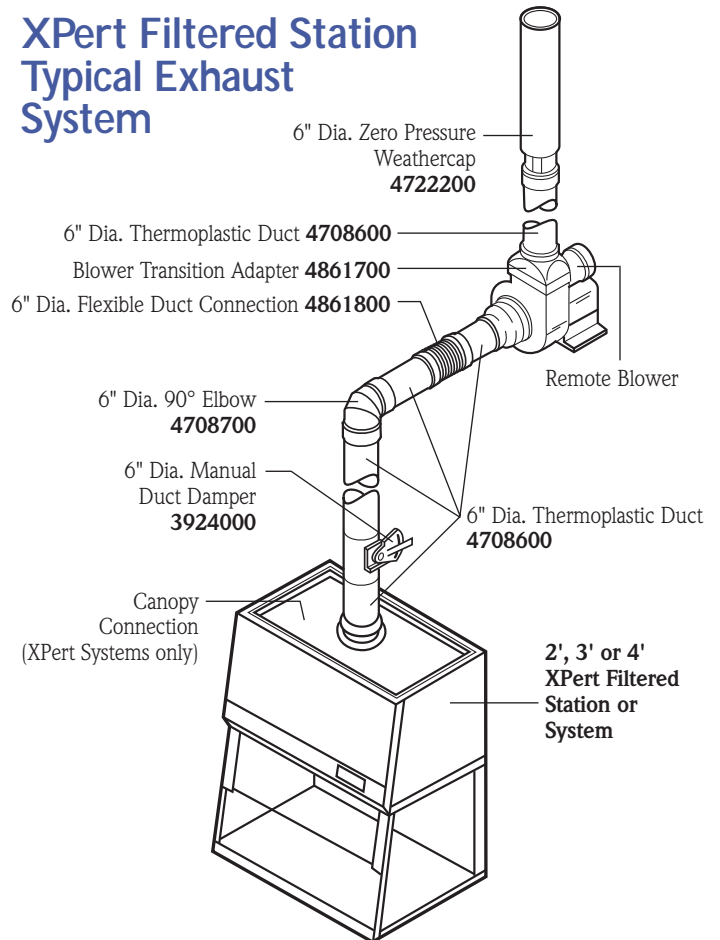

Contact Labconco for ordering information on PVC Manual Duct Dampers.



XPert™ Bulk Powder Enclosures and Bulk Powder Filtered Stations

DUCTWORK COMPONENTS

8' XPert Enclosure Typical Exhaust System

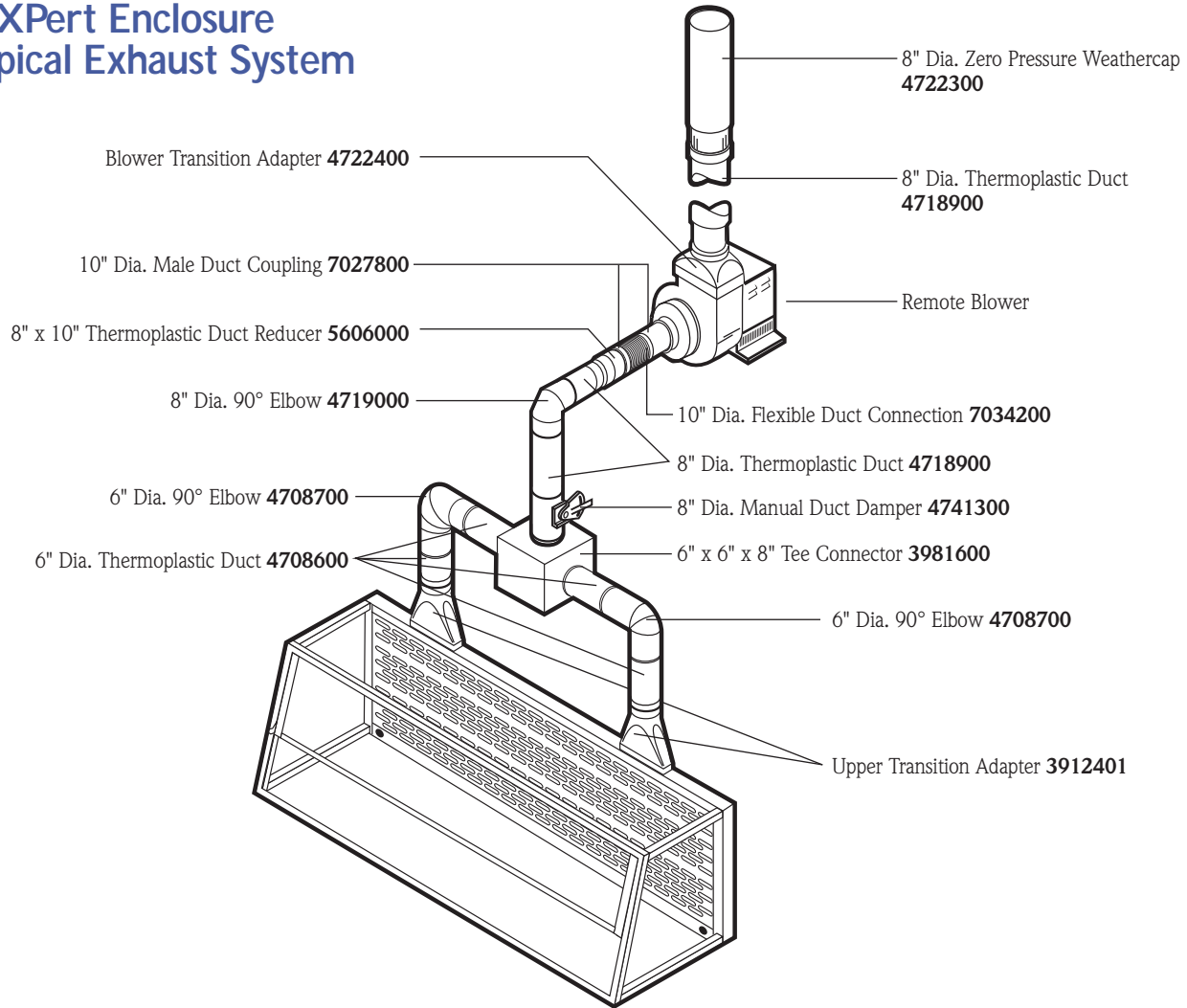

Contact Labconco for more information about these quality products for your laboratory.



Fume Hoods and Carbon-Filtered Enclosures



HEPA-Filtered Safety Cabinets, Clean Benches and Enclosures

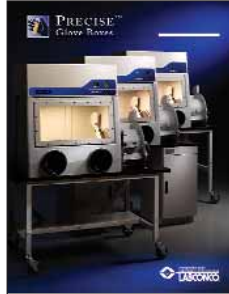

Glove Boxes



Laboratory Animal Research Stations



Water Purification Systems



Freeze Dry Systems



Centrifugal Concentrators and Cold Traps



Multiple Sample Evaporation Systems



Agricultural Chemistry Products



Laboratory Carts and Benches



Labconco Corporation

8811 Prospect Avenue

Kansas City, MO 64132-2696

Telephone: 800-821-5525 or 816-333-8811

FAX: 816-363-0130

E-MAIL: labconco@labconco.com

HOME PAGE: www.labconco.com

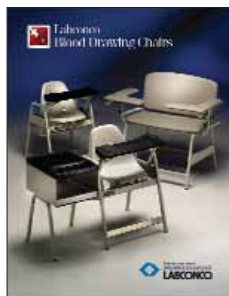

Blood Drawing Chairs



Digital Chloridometers



Vacuum Desiccator

